



# THICK TURRET TOOLING



■ Ketec Precision Tooling Co., Ltd  
Manufacturing CNC Punch Tooling



■ Ketec Precision Tooling Co., Ltd  
Manufacturing Press Brake Tooling

## ***KETEC CHINA SERVE THE WORLD***

---

### **The biggest sheet metal tooling manufacturer in China**

- National High Tech Enterprise
- Registered Capital: 50 Million RMB.
- Fix Assets: 150 Million RMB.
- Total factory area: 506,000 square feet (47,000 square meters).
- Annual Product Capacity: 1,200,000 sets for CNC punch press tooling; 20,000 sets for Press Brake Tooling.
- Over 300 high-quality employees in the company, KETEC have completed machining, EDM, heat treatment.
- National high-tech enterprise, features sheet metal technology R&D center.
- Obtains 18 national invention and new utility patent.
- Over 10,000 sheet metal enterprises in the world are using KETEC TOOLS
- 24 Direct sales in China and 18 KETEC Agents in the global countries.

- 1998 Sept. Founded Jiangnan Mold Tools Factory in Guangzhou.  
Manufacturing stamping tooling.
- 2001 Aug. Established Ketec Precision Tooling Co.,Ltd.  
Manufacturing CNC punch tooling and stamping tooling.
- 2004 Feb. Registered **KETEC**<sup>®</sup> trademark.
- 2004 Aug. ISO9000:2000 certified.
- 2004 Nov. Registered **KETEC**<sup>®</sup> as an international trademark.
- 2007 Dec. Registered enterprise value increasing to 5 Million RMB.
- 2008 Jan. Move to Mingzhu Industrial Park in Conghua Guangzhou with  
approximately 323,000 square feet (30,000 square meters).
- 2008 Jan. Registered enterprise value increasing to 10 Million RMB.
- 2008 Mar. Awarded Guangdong Major Products certificate  
for CNC punch tooling.
- 2008 Jun. Created guideline with permission from Standardization  
Administration of People' s Republic of China for CNC Turret  
Punch Tooling standard.
- 2010 Feb. Published JB/T 10928–2010, CNC Turret Punch Tooling standard  
by China Ministry of Industry and Information.  
Implemented in July 2010.
- 2010 Nov. ISO 9001:2008 Certified.
- 2011 Jun. Started selling TOP series thick turret tooling.
- 2011 Nov. Setup warehouse in Taicang Jiangsu.
- 2012 Mar. Registered enterprise value increasing to 50 Million RMB.
- 2012 Jul. Rated as National High Tech Enterprise.  
Certification No: GR201244000059
- 2012 Aug. Second location completed in Industrial Nan Road  
Conghua Guangzhou with approximately 183000 square feet  
(17000 square meters). Manufacturing press brake tooling.
- 2012 Aug. Established KETEC Precision Tooling Inc. in USA.
- 2013 Oct. Setup warehouse in Tianjin.
- 2015 Oct. Honored the Integrity of Law–Abiding business model in Guangzhou.

# CONTENTS

**M85**  
**M85 ABS**  
**P1-P3**

**E80**  
**P23-P24**

**SHAPE**  
**CLASSES**  
**P65-P66**

**TOP85**  
**TOP85 ABS**  
**P4-P9**

**SPECIAL**  
**TOOLING**  
**P25-P35**

**E85**  
**P10-P15**

**FORMING**  
**TOOLING**  
**P36-P52**

**TOP90**  
**TOP90 ABS**  
**P16-P20**

**SHEET METAL**  
**ACCESSORIES**  
**P53-P60**

**KU TOOLING**  
**(ULTRA)**  
**P21-P22**

**OVERVIEW**  
**P61-P64**



## ■ **M85**    ■ **M85ABS**

- M85 / M85 ABS is quick adjust tooling, including A / B stations.
- Punch assy of A/B station is KETEC patent technology, punch grind life is 5mm [0.20"].
- M 85 equip with standard 85 punch, close guide; M85 ABS equip with 85 ABS punch, closed guide.
- Max. thickness: Mild steel A station 3.8 mm [0.15"], B stations: 6.3mm [0.25"].
- Punch assy of A/B station is KETEC patent technology, punch grind life is 5mm [0.20"], quick adjusting.
- Complete set tooling includes punch assy and die.
- Punch assy is installed in upper turret of the CNC punch machine.

# M85 M85ABS

## A STATION (1.6–12.7mm) [1/2"]

### Solid Guide



Description	M85	M85 ABS
<b>Punch Ass'y</b>		
Round (0°)	HY.AA1RO.	HN.AA1RO.
Square(0°, 135°)	HY.AA3SQ.	HN.AA3SQ.
STD Shape (0°, 90°)	HY.AA2**.	HN.AA2**.
Other (0°, 90°)	HY.AA2**.	HN.AA2**.
<b>Punch</b>		
Round(no pin)	HT.AP1RO.	HK.AP1RO.
STD shape(pin)	HT.AP2**.	HK.AP2**.
Other(pin)	HT.AP2**.	HK.AP2**.
<b>Die</b>		
Round(no pin)	HT.AD1RO.	HT.AD1RO.
STD shape(pin)	HT.AD2**.	HT.AD2**.
Other(pin)	HT.AD2**.	HT.AD2**.
<b>Guide</b>		
Round (0°)	HT.AG1RO.	HN.AG1RO.
Shape (0°,90°)	HT.AG2**.	HN.AG2**.
Square (0°,135°)	HT.AG3SQ.	HN.AG3SQ.
<b>Punch head ass'y</b>	HY.AH9	HY.AH9

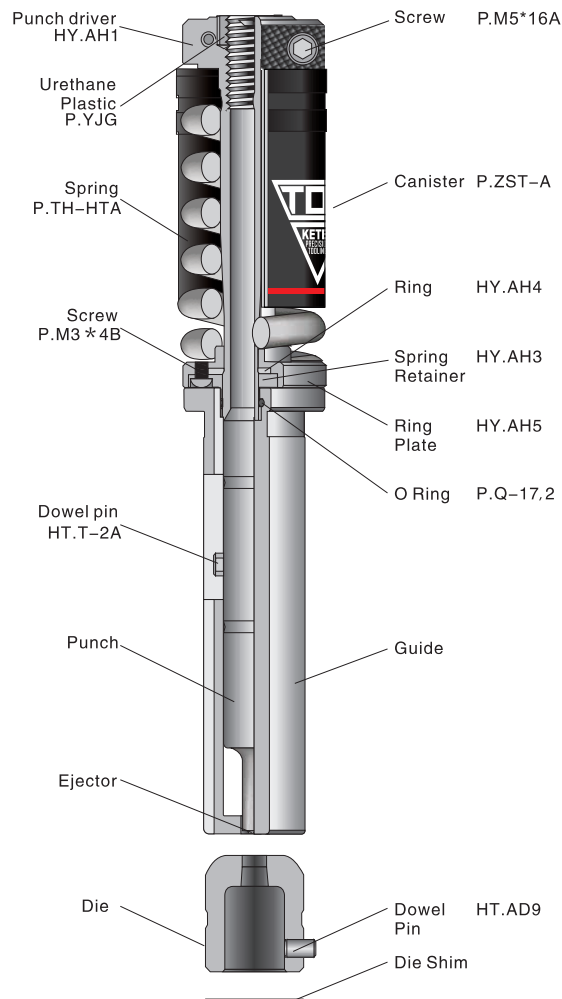



# M85 M85ABS B STATION (12.71–31.7mm) [1-1/4"]

**Solid Guide**

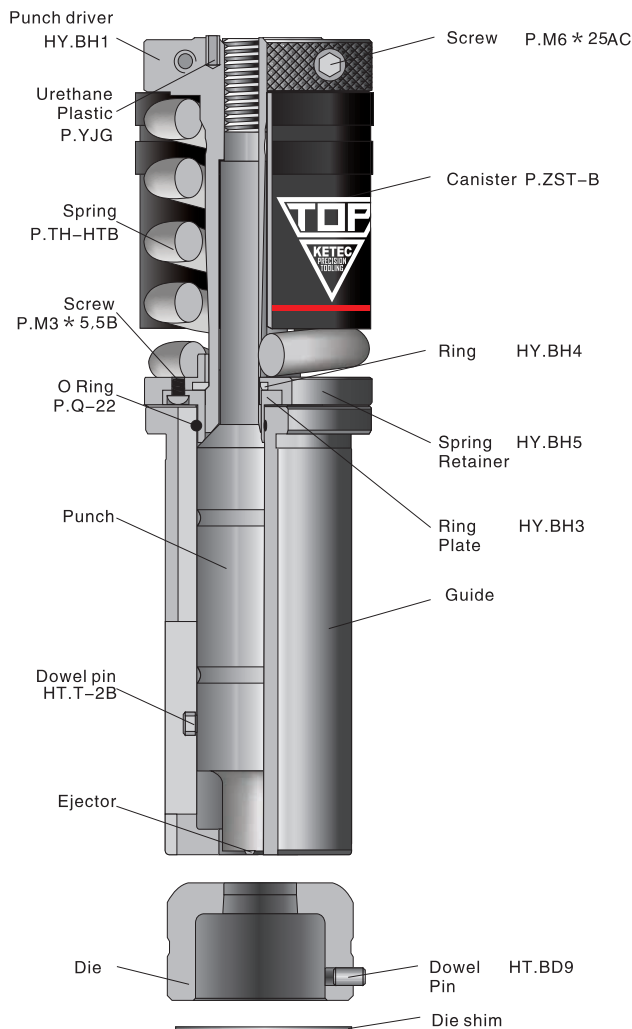

Discription	M85	M85 ABS
<b>Punch Ass'y</b>		
Round (0°)	HY.BA1RO.	HN.BA1RO.
Square(0°, 135°)	HY.BA3SQ.	HN.BA3SQ.
STD Shape (0°, 90°)	HY.BA2**.	HN.BA2**.
Other (0°, 90°)	HY.BA2**.	HN.BA2**.
<b>Punch</b>		
Round(no pin)	HT.BP1RO.	HK.BP1RO.
STD shape(pin)	HT.BP2**.	HK.BP2**.
Other(pin)	HT.BP2**.	HK.BP2**.
<b>Die</b>		
Round(no pin)	HT.BD1RO.	HT.BD1RO.
STD shape(pin)	HT.BD2**.	HT.BD2**.
Other(pin)	HT.BD2**.	HT.BD2**.
<b>Guide</b>		
Round (0°)	HT.BG1RO.	HN.BG1RO.
Shape (0°, 90°)	HT.BG2**.	HN.BG2**.
Square (0°, 135°)	HT.BG3SQ.	HN.BG3SQ.
<b>Punch head ass'y</b>	HY.BH9	HY.BH9



## ■ TOP85      ■ TOP85ABS

- TOP85 series are Q-Adjust tooling, including A / B / C / D / E stations.
- Guide assy of C/D/E station is KETEC patent technology, with standard 85 punch / ABS punch & stripper.
- Standard key slots on the guides of C/D/E station are divided into 0° , 90° , 135° , good performance.
- Punch grind life of C/D/E station is 5–8mm [0.20"~0.31"], quick adjusting, without shim.
- Punch assy of A/B station is KETEC patent technology, punch grind life is 5mm [0.20"], quick adjusting.
- Top 85 equip with standard 85 punch, open guide, 90 stripper.
- Top 85 ABS equip with 85 ABS punch, open guide, 90 ABS stripper.
- Max. thickness: Mild steel A station 3.8 mm [0.15"], other stations: 6.3mm [0.25"]
- Complete set tooling includes punch assy and die.
- Punch assy is installed in upper turret of the CNC punch machine.

# TOP85 TOP85ABS

## A STATION (1.6–12.7mm) [1/2"]

Open Guide

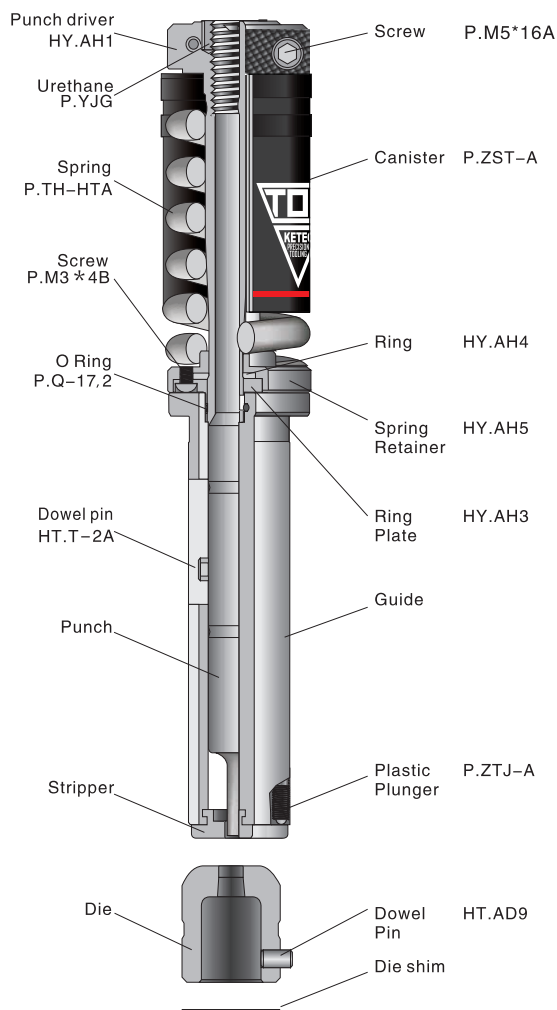

Discription	TOP85	TOP85 ABS
<b>Punch ass'y</b>		
Round (0°)	HV.AA1RO.	HK.AA1RO.
Square (0°, 135°)	HV.AA3SQ.	HK.AA3SQ.
STD shape (0°, 90°)	HV.AA2**.	HK.AA2**.
Other (0°, 90°)	HV.AA2**.	HK.AA2**.
<b>Punch</b>		
Round(no pin)	HT.AP1RO.	HK.AP1RO.
STD shape(pin)	HT.AP2**.	HK.AP2**.
Other(pin)	HT.AP2**.	HK.AP2**.
<b>Stripper</b>		
Round	H9.AS1RO.	HP.AS1RO.
STD shape	H9.AS1**.	HP.AS1**.
Other	H9.AS1**.	HP.AS1**.
<b>Die</b>		
Round(no pin)	HT.AD1RO.	HT.AD1RO.
STD shape(pin)	HT.AD2**.	HT.AD2**.
Other(pin)	HT.AD2**.	HT.AD2**.
<b>Guide</b>		
Round(0°)	HV.AG1	HK.AG1
Shape(0°, 90°)	HV.AG2	HK.AG2
Square (0°, 135°)	HV.AG3	HK.AG3
<b>Punch head ass'y</b>		
	HY.AH9	HY.AH9

# TOP85 TOP85ABS

**B STATION**  
**(12.71–31.7mm)**  
**[1-1/4"]**

**Open Guide**



Discription	TOP85	TOP85 ABS
<b>Punch ass'y</b>		
Round (0°)	HV.BA1RO.	HK.BA1RO.
Square (0°, 135°)	HV.BA3SQ.	HK.BA3SQ.
STD shape(0°, 90°)	HV.BA2**.	HK.BA2**.
Other (0, 90°)	HV.BA2**.	HK.BA2**.
<b>Punch</b>		
Round(no pin)	HT.BP1RO.	HK.BP1RO.
STD shape(pin)	HT.BP2**.	HK.BP2**.
Other(pin)	HT.BP2**.	HK.BP2**.
<b>Stripper</b>		
Round	H9.BS1RO.	HP.BS1RO.
STD shape	H9.BS1**.	HP.BS1**.
Other	H9.BS1**.	HP.BS1**.
<b>Die</b>		
Round(no pin)	HT.BD1RO.	HT.BD1RO.
STD shape(pin)	HT.BD2**.	HT.BD2**.
Other (pin)	HT.BD2**.	HT.BD2**.
<b>Guide</b>		
Round (0°)	HV.BG1	HK.BG1
Shape (0°,90°)	HV.BG2	HK.BG2
Square(0°,135°)	HV.BG3	HK.BG3
<b>Punch head ass'y</b>	HY.BH9	HY.BH9

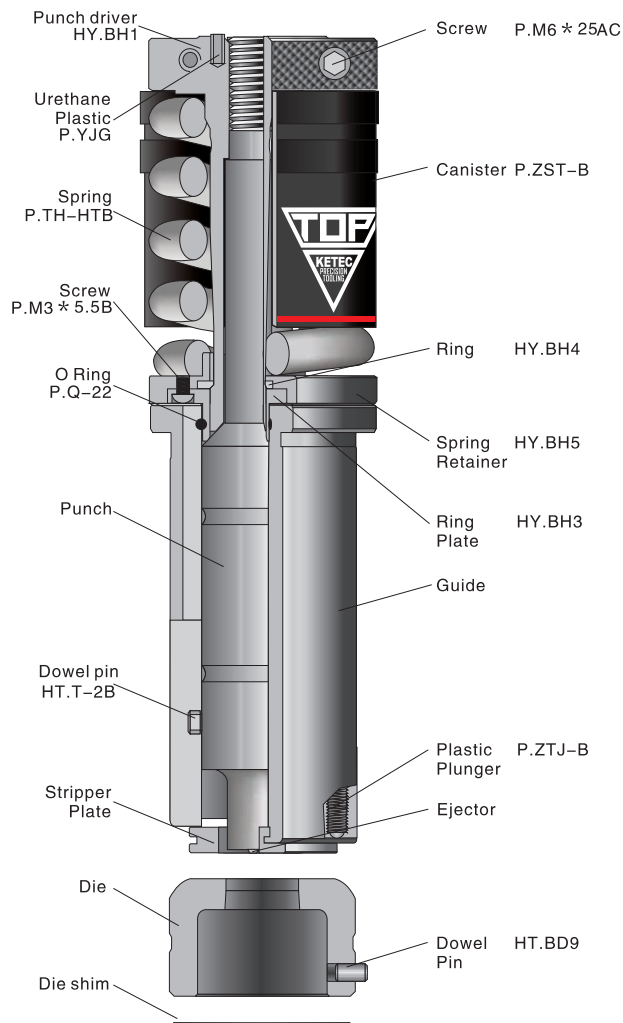



# TOP85 TOP85ABS C STATION (31.71–50.8mm) [2"]

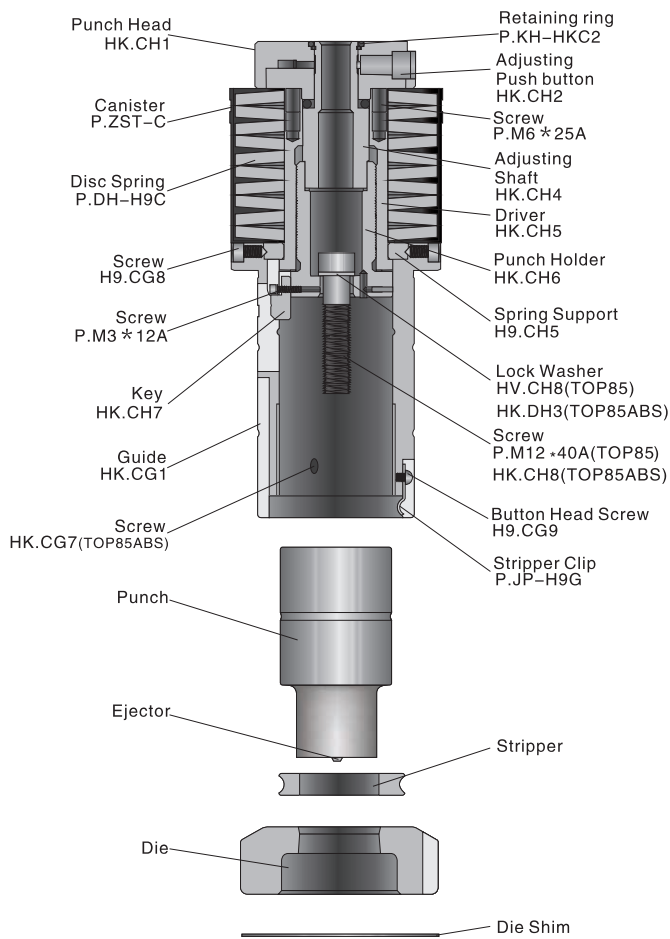

Description	TOP85	TOP85 ABS
<b>Punch ass'y</b>		
Round	HV.CA1RO.	HK.CA1RO.
STD shape	HV.CA1**.	HK.CA1**.
Other	HV.CA1**.	HK.CA1**.
<b>Guide ass'y</b>	HV.CC1.	HK.CC1.
<b>Punch</b>		
Round	HT.CP1RO.	HK.CP1RO.
STD shape	HT.CP2**.	HK.CP2**.
Other	HT.CP2**.	HK.CP2**.
<b>Stripper</b>		
Round	HT.CS1RO.	HK.CS1RO.
STD shape	HT.CS1**.	HK.CS1**.
Other	HT.CS1**.	HK.CS1**.
<b>Die</b>		
Round (0°)	HT.CD1RO.	HT.CD1RO.
STD shape (0°, 90°)	HT.CD2**.	HT.CD2**.
Other (0°, 90°)	HT.CD2**.	HT.CD2**.
Square (Opt. 0°, 135°)	HT.CD3SQ.	HT.CD3SQ.

# TOP85 TOP85ABS D STATION (50.81-88.9mm) [3-1/2"]



Description	TOP85	TOP85 ABS
<b>Punch ass'y</b>		
Round	HV.DA1RO.	HK.DA1RO.
STD shape	HV.DA1**.	HK.DA1**.
Other	HV.DA1**.	HK.DA1**.
<b>Guide ass'y</b>	HV.DC1.	HK.DC1.
<b>Punch</b>		
Round	HT.DP1RO.	HK.DP1RO.
STD shape	HT.DP2**.	HK.DP2**.
Other	HT.DP2**.	HK.DP2**.
<b>Stripper</b>		
Round	HT.DS1RO.	HK.DS1RO.
STD shape	HT.DS1**.	HK.DS1**.
Other	HT.DS1**.	HK.DS1**.
<b>Die</b>		
Round (0°)	HT.DD1RO.	HT.DD1RO.
STD shape (0°,90°)	HT.DD2**.	HT.DD2**.
Other (0°,90°)	HT.DD2**.	HT.DD2**.
Square (Opt.0°,135°)	HT.DD3SQ.	HT.DD3SQ.

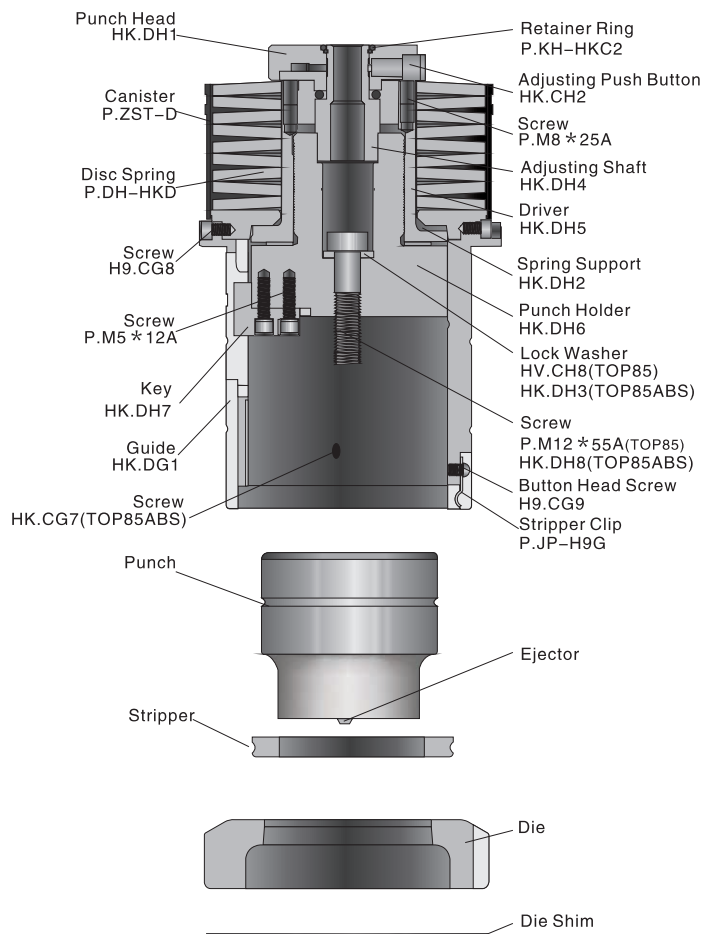



# TOP85 TOP85ABS E STATION

(88.91–114.3mm)  
[4-1/2"]

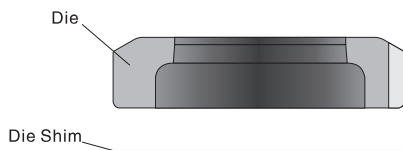
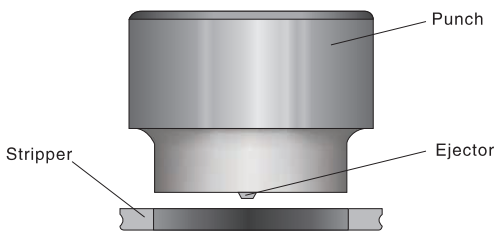
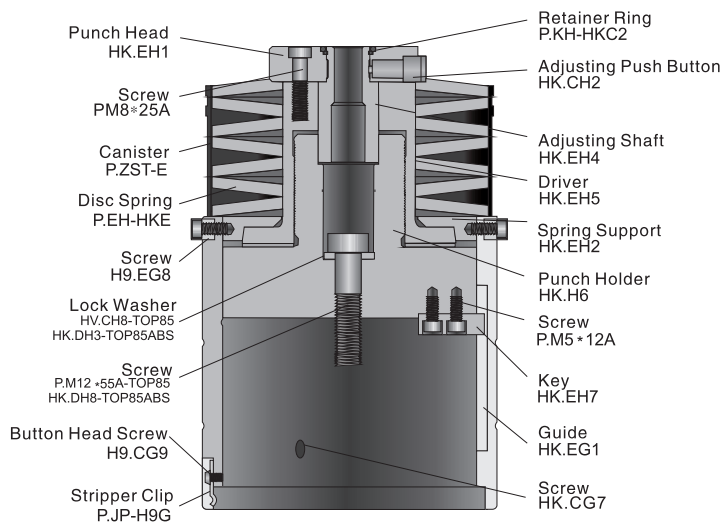

Description	TOP85	TOP85 ABS
<b>Punch ass'y</b>		
Round	HV.EA1RO.	HK.EA1RO.
STD shape	HV.EA1**.	HK.EA1**.
Other	HV.EA1**.	HK.EA1**.
<b>Guide ass'y</b>		
	HV.EC1.	HK.EC1.
<b>Punch</b>		
Round	HT.EP1RO.	HK.EP1RO.
STD shape	HT.EP2**.	HK.EP2**.
Other	HT.EP2**.	HK.EP2**.
<b>Stripper</b>		
Round	HT.ES1RO.	HK.ES1RO.
STD shape	HT.ES1**.	HK.ES1**.
Other	HT.ES1**.	HK.ES1**.
<b>Die</b>		
Round (0°)	HT.ED1RO.	HT.ED1RO.
STD shape (0°,90°)	HT.ED2**.	HT.ED2**.
Other (0°,90°)	HT.ED2**.	HT.ED2**.
Square (Opt.0°,135°)	HT.ED3SQ.	HT.ED3SQ.



## ■ E85

- E85 series are standard tools, including station A/B/C/D/E, compatible with Amada tooling.
- Standard key slots on the guides of A/B station are  $0^\circ$ ,  $90^\circ$ , square are  $0^\circ$ ,  $135^\circ$ .
- The tapers on spring retainers of A/B station are different, the grind life will be extended with exchange using.
- Max. thickness: Mild Steel for A station is 3.8mm [0.15"], other station is 6.3mm [0.25"].
- Complete set tooling includes punch assy and die.
- Punch assy is installed in upper turret of the CNC punch machine.

# E85

## A STATION ( 1.6~12.7mm ) [ 1/2" ]

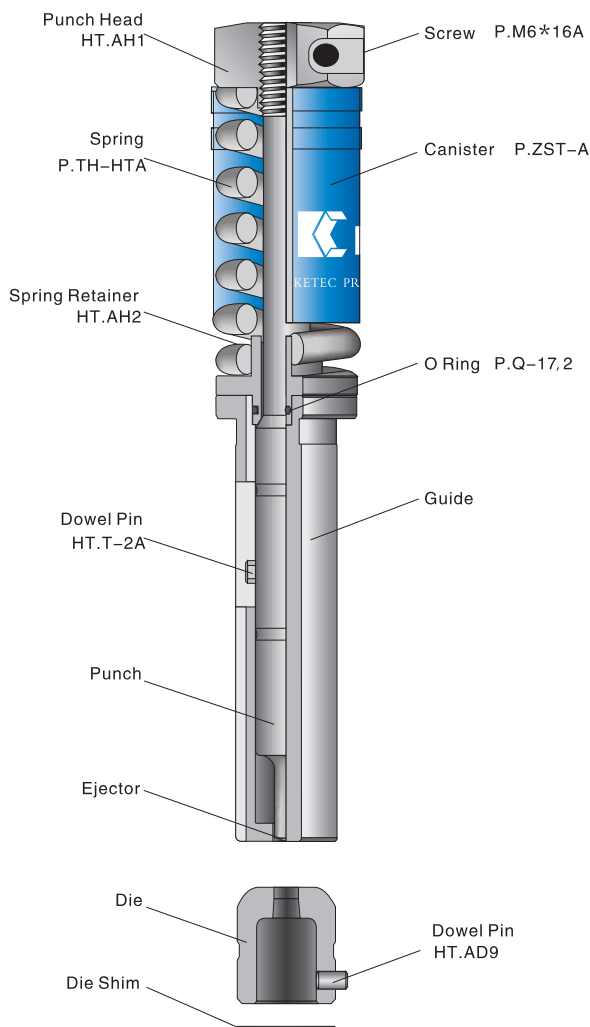

Description	Code
<b>Punch ass'y</b>	
Round (0°)	HT.AA1RO.
Square (0°, 135°)	HT.AA3SQ.
STD shape (0°, 90°)	HT.AA2**.
Other (0°, 90°)	HT.AA2**.
<b>Punch</b>	
Round (no pin)	HT.AP1RO.
STD shape (pin)	HT.AP2**.
Other (pin)	HT.AP2**.
<b>Die</b>	
Round (no pin)	HT.AD1RO.
STD shape (pin)	HT.AD2**.
Other (pin)	HT.AD2**.
<b>Guide</b>	
Round (0°)	HT.AG1RO.
Shape (0°, 90°)	HT.AG2**.
Square (0°, 135°)	HT.AG3SQ.
<b>Punch head ass'y</b>	HT.AH9

# E85

## B STATION (12.71–31.7mm) [1-1/4"]



### Description

#### Punch ass'y

Round (0°)  
Square (0°, 135°)  
STD shape (0°, 90°)  
Other (0°, 90°)

#### Punch

Round (no pin)  
STD shape (pin)  
Other (pin)

#### Die

Round (no pin)  
STD shape (pin)  
Other (pin)

#### Guide

Round (0°)  
Shape (0°, 90°)  
Square (0°, 135°)

#### Punch head ass'y

### Code

HT.BA1RO.  
HT.BA3SQ.  
HT.BA2\*\*.  
HT.BA2\*\*.

HT.BP1RO.  
HT.BP2\*\*.  
HT.BP2\*\*.

HT.BD1RO.  
HT.BD2\*\*.  
HT.BD2\*\*.

HT.BG1RO.  
HT.BG2\*\*.  
HT.BG3SQ.

HT.BH9

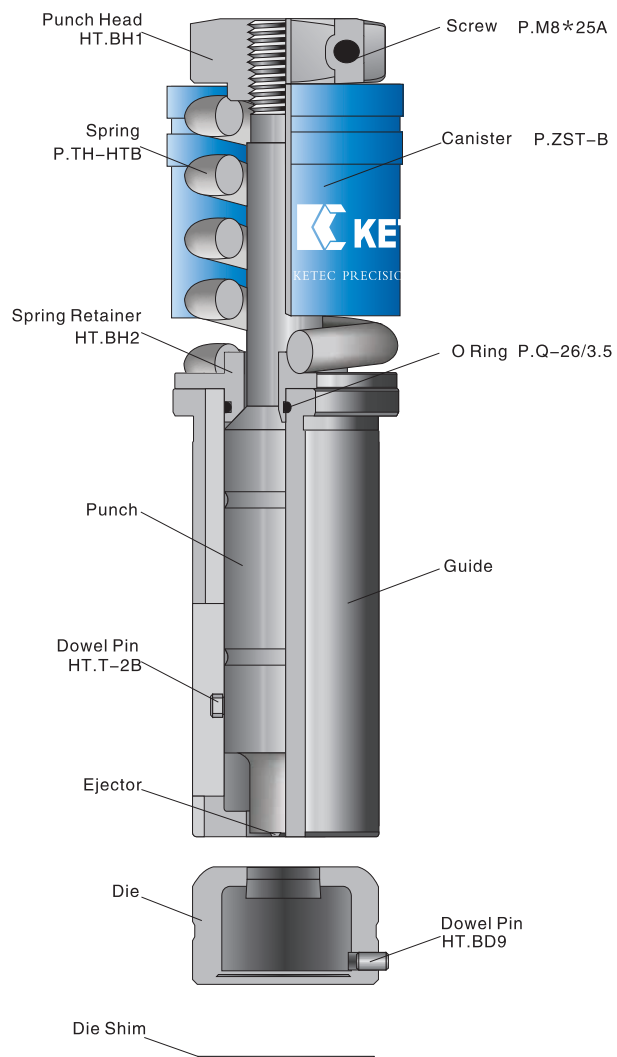



# E85

## C STATION (31.71–50.8mm) [2"]

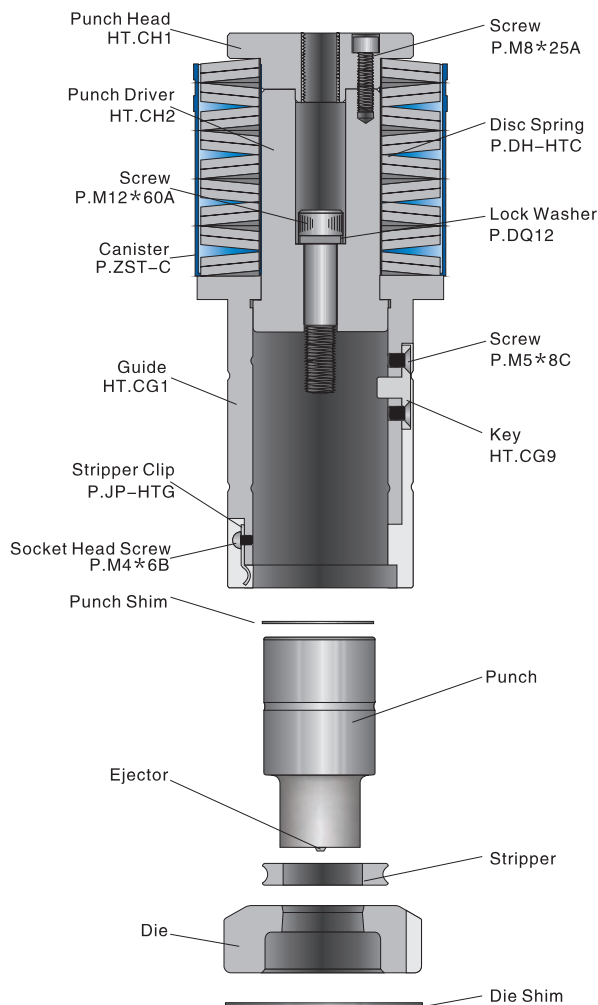

Description	Code
<b>Punch ass'y</b>	
Round	HT.CA1RO.
STD shape	HT.CA1**.
Other	HT.CA1**.
<b>Guide ass'y (0°,90°)</b>	HT.CC1.
<b>Punch</b>	
Round	HT.CP1RO.
STD shape	HT.CP2**.
Other	HT.CP2**.
Square (Opt.0°,135°)	HT.CP3SQ.
<b>Stripper</b>	
Round	HT.CS1RO.
STD shape	HT.CS1**.
Other	HT.CS1**.
<b>Die</b>	
Round(0°)	HT.CD1RO.
STD shape (0°,90°)	HT.CD2**.
Other (0°,90°)	HT.CD2**.
Square (Opt.0°,135°)	HT.CD3SQ.

# E85

## D STATION (50.81–88.9mm) [3-1/2"]



### Description

#### Punch ass'y

Round  
STD Shape  
Other

#### Guide ass'y

#### Punch

Round (0°)  
STD shape (0°)  
Other (0°)  
Square (Opt. 0°, 45°)

#### Stripper

Round  
STD shape  
Other

#### Die

Round (0°)  
STD shape (0°, 90°)  
Other (0°, 90°)  
Square (Opt. 0°, 135°)

### Code

HT.DA1RO.  
HT.DA1\*\*.  
HT.DA1\*\*.  
HT.DC1.

HT.DP1RO.  
HT.DP2\*\*.  
HT.DP2\*\*.  
HT.DP3SQ.

HT.DS1RO.  
HT.DS1\*\*.  
HT.DS1\*\*.

HT.DD1RO.  
HT.DD2\*\*.  
HT.DD2\*\*.  
HT.DD3SQ.

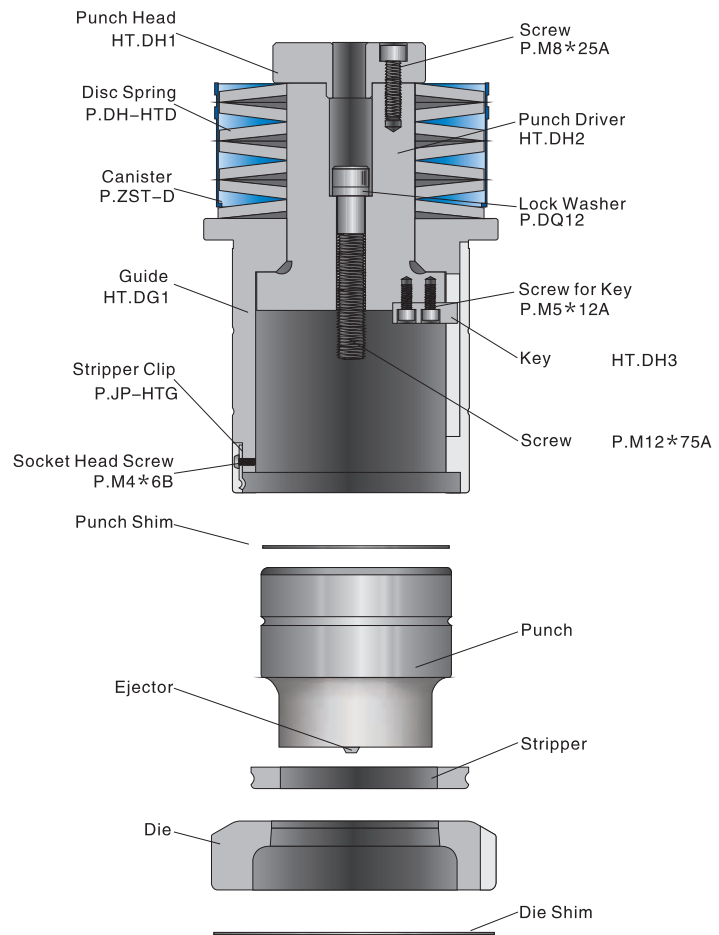



# E85

## E STATION (88.91–114.3mm) [4-1/2"]

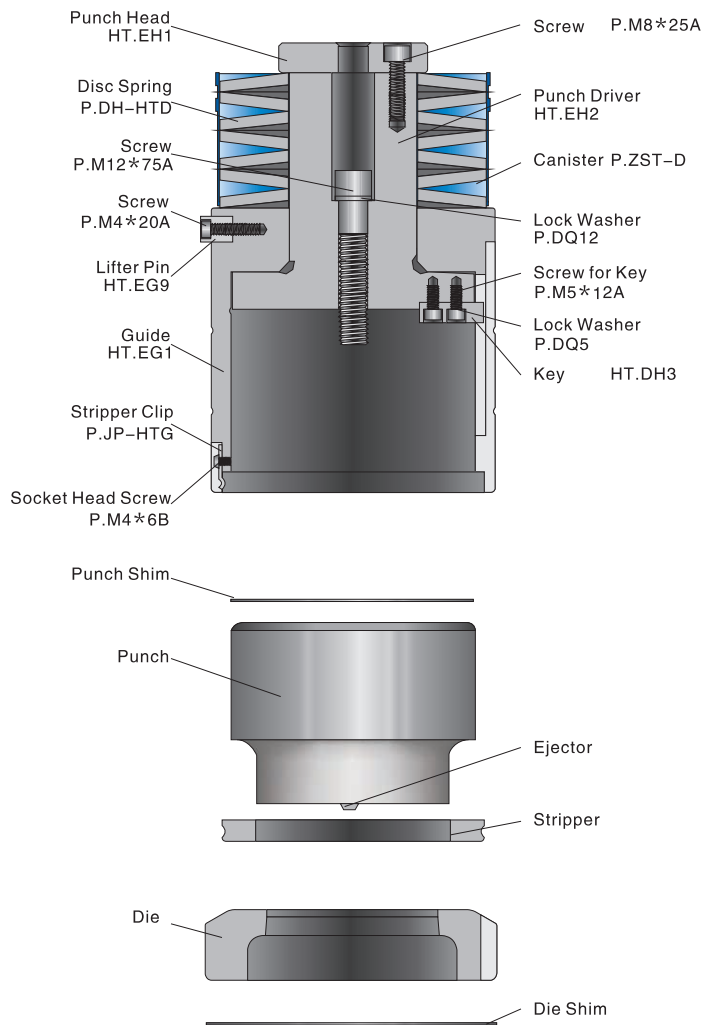

Discription	Code
<b>Punch ass'y</b>	
Round	HT.EA1RO.
STD shape	HT.EA1**.
Other	HT.EA1**.
<b>Guide ass'y(0°,90°)</b>	HT.EC1.
<b>Punch</b>	
Round (0°)	HT.EP1RO.
STD shape (0°)	HT.EP2**.
Other (0°)	HT.EP2**.
<b>Stripper</b>	
Round	HT.ES1RO.
STD shape	HT.ES1**.
Other	HT.ES1**.
<b>Die</b>	
Round (0°)	HT.ED1RO.
STD shape (0°,90°)	HT.ED2**.
Other (0°,90°)	HT.ED2**.



## ■ TOP90 ■ TOP90ABS

- TOP90 series tooling, including station A/B/C/D.
- Guide assy of C/D station is KETEC patent technology, with standard 90 punch, 90 stripper.
- Punch head assy of A/B station is KETEC patent technology, with standard 90 punch / ABS punch / stripper.
- The punch grind life of A/B station is 6.3mm [0.25"] quick adjusting, w/o shim.
- The punch grind life of C/D station is 5–8mm [0.20"~0.31"], quick adjusting, w/o shim.
- Standard key slots on the guides of C/D station with 0°, 90°, 135°, good performance.
- Max thickness: Mild Steel for A station is 3.8mm [0.15"], for others stations is 6.3mm [0.25"]
- Complete set tooling includes punch assy and die.
- Punch assy is installed in upper turret of the CNC punch machine.

# TOP90 TOP90ABS A STATION (1.6–12.7mm) [1/2"]

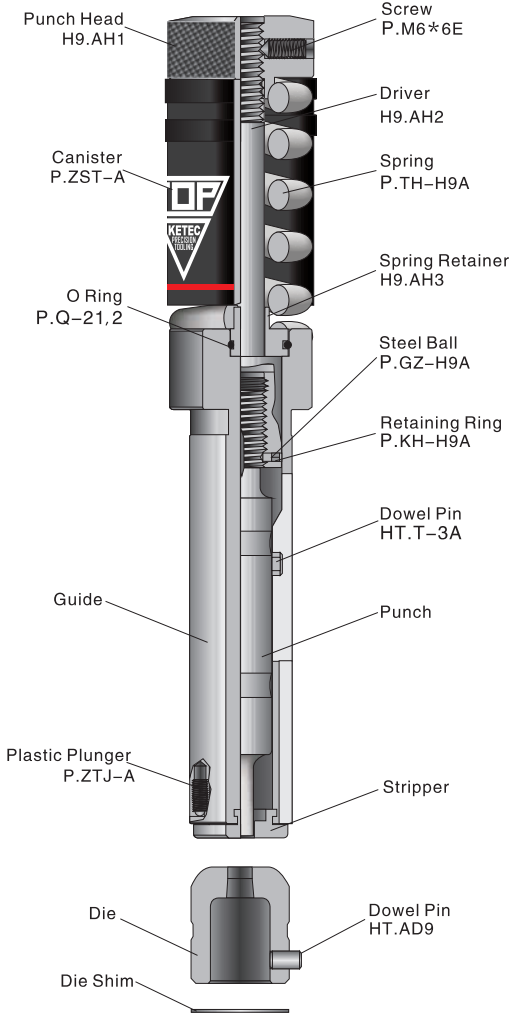

Description	TOP90	TOP90 ABS
<b>Punch ass'y</b>		
Round (0°)	H9.AA1RO.	HP.AA1RO.
Square (0°, 135°)	H9.AA3SQ.	HP.AA3SQ.
STD shape (0°, 90°)	H9.AA2**.	HP.AA2**.
Other (0°, 90°)	H9.AA2**.	HP.AA2**.
<b>Punch</b>		
Round (no pin)	H9.AP1RO.	HP.AP1RO.
STD shape (pin)	H9.AP2**.	HP.AP2**.
Other (pin)	H9.AP2**.	HP.AP2**.
<b>Stripper</b>		
Round	H9.AS1RO.	HP.AS1RO.
STD shape	H9.AS1**.	HP.AS1**.
Other	H9.AS1**.	HP.AS1**.
<b>Die</b>		
Round (no pin)	HT.AD1RO.	HT.AD1RO.
STD shape (pin)	HT.AD2**.	HT.AD2**.
Other (pin)	HT.AD2**.	HT.AD2**.
<b>Guide</b>		
Round (0°)	H9.AG1	HP.AG1
Shape (0°, 90°)	H9.AG2	HP.AG2
Square (0°, 135°)	H9.AG3	HP.AG3
<b>Punch head ass'y</b>	H9.AH9	H9.AH9

# TOP90 TOP90ABS B STATION (12.71–31.7mm) [1-1/4"]



Description	TOP90	TOP90 ABS
<b>Punch ass'y</b>		
Round (0°)	H9.BA1RO.	HP.BA1RO.
Square (0°, 135°)	H9.BA3SQ.	HP.BA3SQ.
STD shape (0°, 90°)	H9.BA2**.	HP.BA2**.
Other (0°, 90°)	H9.BA2**.	HP.BA2**.
<b>Punch</b>		
Round (no pin)	H9.BP1RO.	HP.BP1RO.
STD shape (pin)	H9.BP2**.	HP.BP2**.
Other (pin)	H9.BP2**.	HP.BP2**.
<b>Stripper</b>		
Round	H9.BS1RO.	HP.BS1RO.
STD shape	H9.BS1**.	HP.BS1**.
Other	H9.BS1**.	HP.BS1**.
<b>Die</b>		
Round (no pin)	HT.BD1RO.	HT.BD1RO.
STD shape (pin)	HT.BD2**.	HT.BD2**.
Other (pin)	HT.BD2**.	HT.BD2**.
<b>Guide</b>		
Round (0°)	H9.BG1	HP.BG1
Shape (0°, 90°)	H9.BG2	HP.BG2
Square (0°, 135°)	H9.BG3	HP.BG3
<b>Punch head ass'y</b>	H9.BH9	H9.BH9

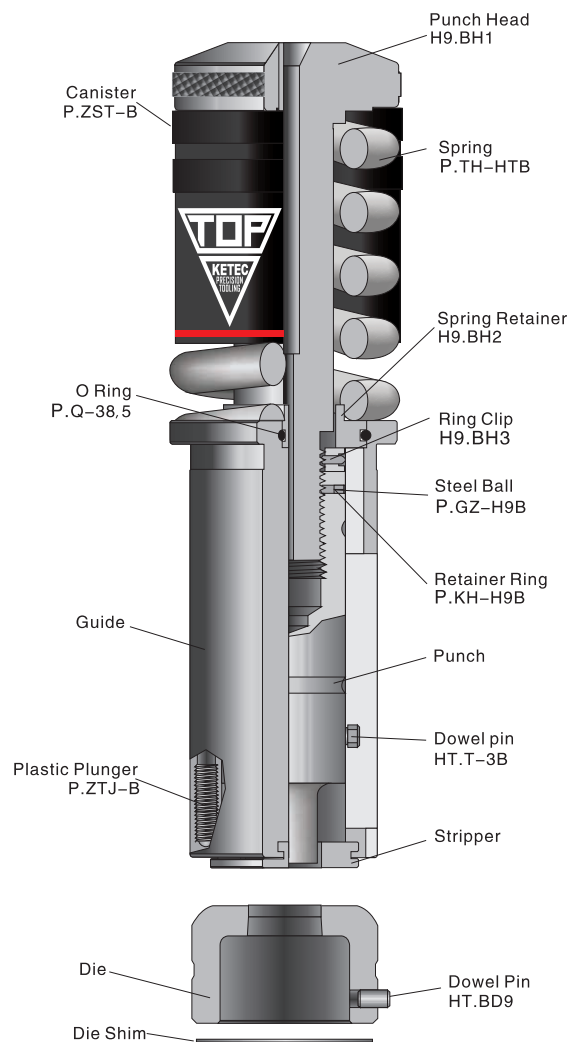

# TOP90 TOP90ABS C STATION (31.71–50.8mm) [2"]

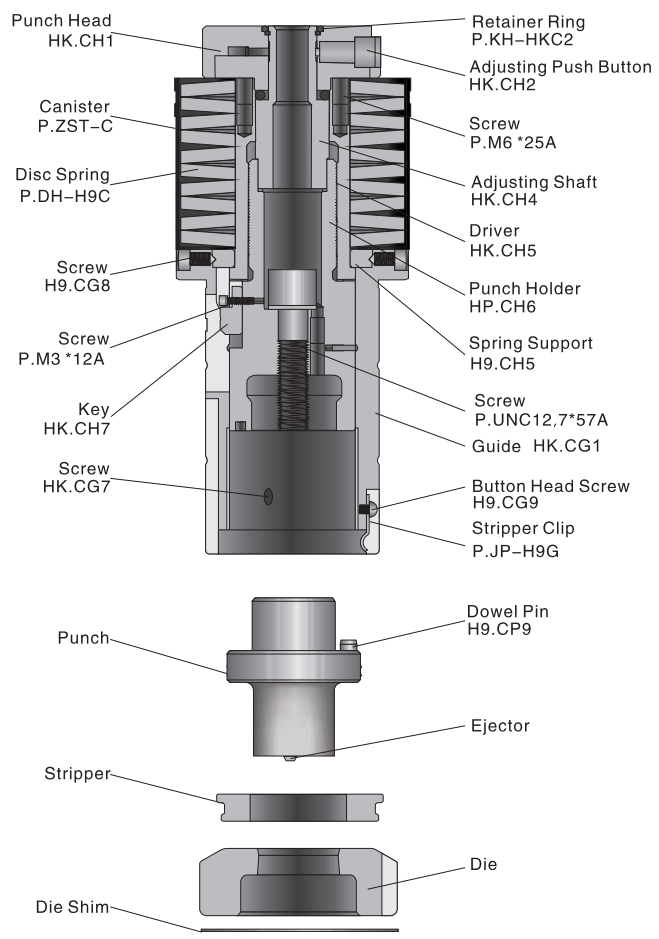

Description	TOP90	TOP90 ABS
<b>Punch ass'y</b>		
Round	HJ.CA1RO.	HP.CA1RO.
STD shape	HJ.CA1**.	HP.CA1**.
Other	HJ.CA1**.	HP.CA1**.
<b>Guide ass'y (0°, 90°, 135°)</b>	HP.CC1.	HP.CC1.
<b>Punch</b>		
Round	H9.CP1RO.	H9.CP1RO.
STD shape	H9.CP1**.	H9.CP1**.
Other	H9.CP1**.	H9.CP1**.
<b>Stripper</b>		
Round	H9.CS1RO.	HP.CS1RO.
STD shape	H9.CS1**.	HP.CS1**.
Other	H9.CS1**.	HP.CS1**.
<b>Die</b>		
Round (0°)	HT.CD1RO.	HT.CD1RO.
STD Shape (0°, 90°)	HT.CD2**.	HT.CD2**.
Other (0°, 90°)	HT.CD2**.	HT.CD2**.
Square (Opt. 0°, 135°)	HT.CD3SQ.	HT.CD3SQ.

# TOP90 TOP90ABS D STATION (50.81–88.9mm) [3-1/2"]



Description	TOP90	TOP90 ABS
<b>Punch ass'y</b>		
Round	HJ.DA1RO.	HP.DA1RO.
STD shape	HJ.DA1**.	HP.DA1**.
Other	HJ.DA1**.	HP.DA1**.
<b>Guide ass'y</b>	HP.DC1.	HP.DC1.
<b>Punch</b>		
Round	H9.DP1RO.	H9.DP1RO.
STD shape	H9.DP1**.	H9.DP1**.
Other	H9.DP1**.	H9.DP1**.
<b>Stripper</b>		
Round	H9.DS1RO.	HP.DS1RO.
STD shape	H9.DS1**.	HP.DS1**.
Other	H9.DS1**.	HP.DS1**.
<b>Die</b>		
Round (0°)	HT.DD1RO.	HT.DD1RO.
STD Shape (0°, 90°)	HT.DD2**.	HT.DD2**.
Other (0°, 90°)	HT.DD2**.	HT.DD2**.
Square (Opt. 0°, 135°)	HT.DD3SQ.	HT.DD3SQ.

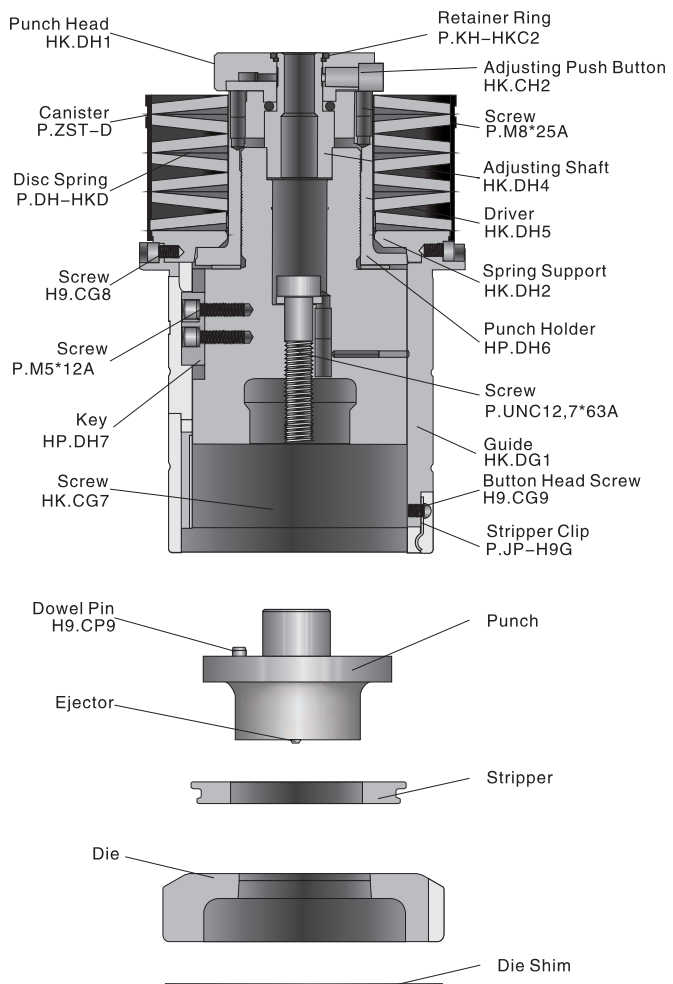



# KU TOOLING A STATION

(1.6–12.7mm)  
[1/2"]

## Ultra Style

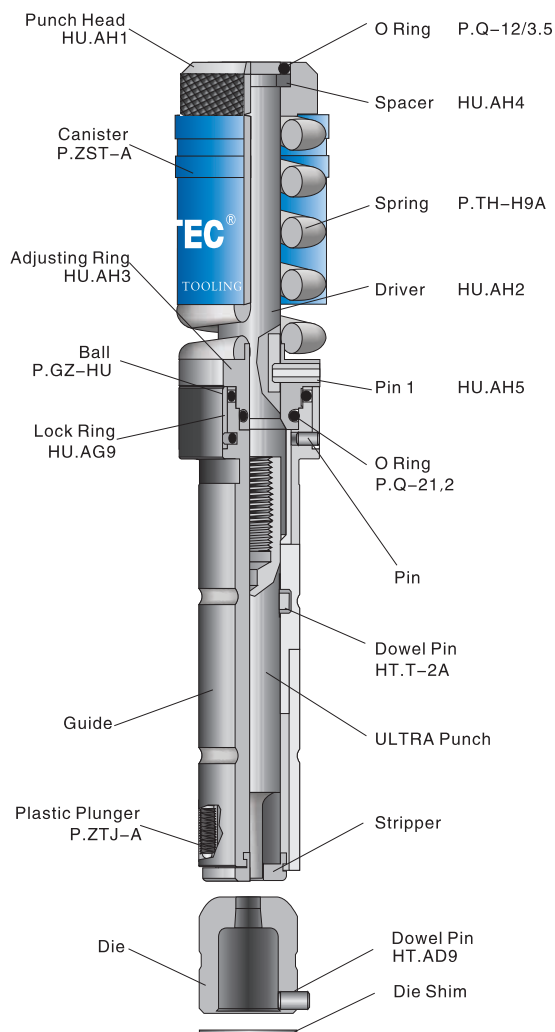

Description	Code
<b>Punch ass'y</b>	
Round (0°)	HU.AA1RO
Square (0°, 135°)	HU.AA3SQ
STD shape (0°, 90°)	HU.AA2**
Other (0°, 90°)	HU.AA2**
<b>Punch</b>	
Round	HU.AP1RO
STD shape	HU.AP1**.
Other	HU.AP1**.
<b>Stripper</b>	
Round	HU.AS1RO
STD shape	HU.AS1**.
Other	HU.AS1**.
<b>Die</b>	
Round (no pin)	HT.AD1RO
STD shape (pin)	HT.AD2**.
Other (pin)	HT.AD2**.
<b>Guide</b>	
Round (0°)	HU.AG1
Shape (0°, 90°)	HU.AG2
Square (0°, 135°)	HU.AG3
<b>Punch head ass'y</b>	HU.AH9

# KU TOOLING B STATION (12.71–31.7mm) [1–1/4"] Ultra Style



Description Code

**Punch ass'y**

Round (0°) HU.BA1RO  
 Square (0°, 135°) HU.BA3SQ  
 STD shape (0°, 90°) HU.BA2\*\*  
 Other (0°, 90°) HU.BA2\*\*

**Punch**

Round HU.BP1RO  
 STD shape HU.BP1\*\*.  
 Other HU.BP1\*\*.

**Stripper**

Round HU.BS1RO  
 Shape HU.BS1\*\*.  
 Other HU.BS1\*\*.

**Die**

Round (no pin) HT.BD1RO  
 STD shape (pin) HT.BD2\*\*.  
 Other (pin) HT.BD2\*\*.

**Guide**

Round (0°) HU.BG1  
 Shape (0°, 90°) HU.BG2  
 Square (0°, 135°) HU.BG3

**Punch head ass'y** HU.BH9

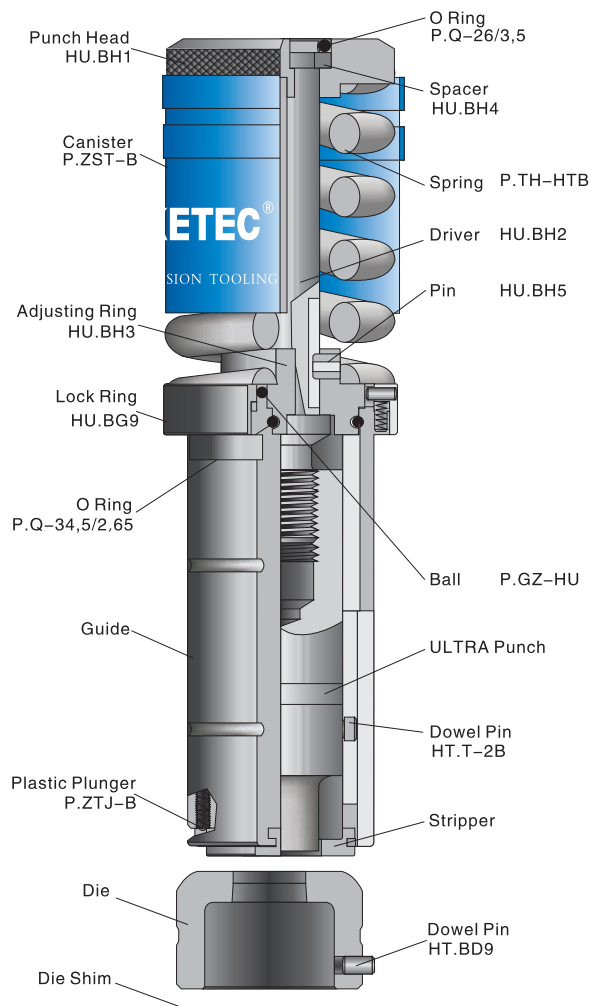

# E80

## A STATION (1.6–12.7mm) [1/2"]

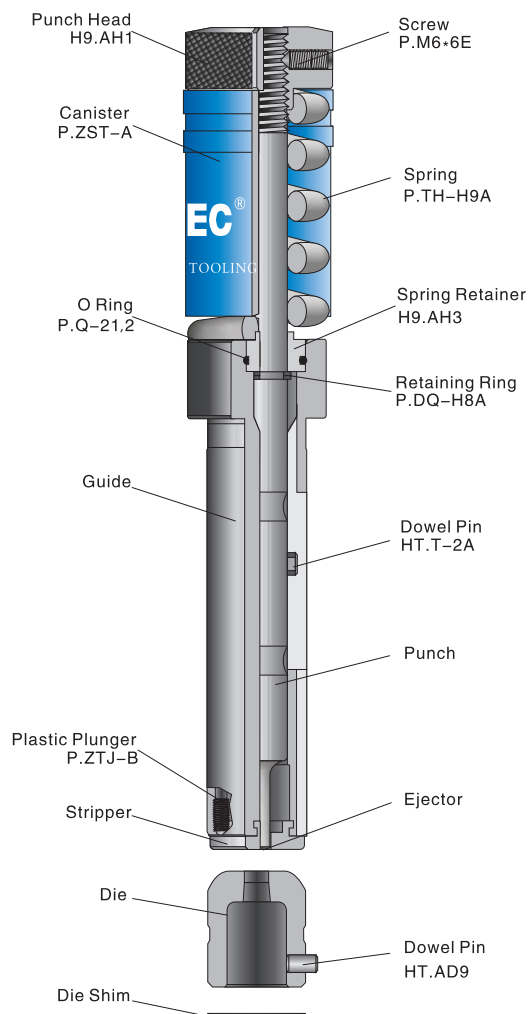

Description	Code
<b>Punch ass'y</b>	
Round (0°)	H8.AA1RO.
Square (0°, 135°)	H8.AA3SQ.
STD shape (0°, 90°)	H8.AA2**.
Other (0°, 90°)	H8.AA2**.
<b>Punch</b>	
Round (no pin)	H8.AP1RO.
STD shape (pin)	H8.AP2**.
Other (pin)	H8.AP2**.
<b>Stripper</b>	
Round	H9.AS1RO.
STD shape	H9.AS1**.
Other	H9.AS1**.
<b>Die</b>	
Round (no pin)	HT.AD1RO.
STD shape (pin)	HT.AD2**.
Other (pin)	HT.AD2**.
<b>Guide (Opt. solid)</b>	
Round (0°)	H8.AG1RO.
Shape (0°, 90°)	H8.AG2**.
Square (0°, 135°)	H8.AG3SQ.
<b>Guide (STD. open)</b>	
Round (0°)	H9.AG1
Shape (0°, 90°)	H9.AG2
Square (0°, 135°)	H9.AG3

# E80

## B STATION (12.71–31.7mm) [1–1/4"]



Description	Code
<b>Punch ass'y</b>	
Round (0°)	H8.BA1RO.
Square (0°, 135°)	H8.BA3SQ.
STD shape (0°, 90°)	H8.BA2**.
Other (0°, 90°)	H8.BA2**.
<b>Punch</b>	
Round (no pin)	H8.BP1RO.
STD shape (pin)	H8.BP2**.
Other (pin)	H8.BP2**.
<b>Stripper</b>	
Round	H8.BS1RO.
STD shape	H8.BS1**.
Other	H8.BS1**.
<b>Die</b>	
Round (no pin)	HT.BD1RO.
STD shape (pin)	HT.BD2**.
Other (pin)	HT.BD2**.
<b>Guide</b>	
Round (0°)	H8.BG1
Shape (0°, 90°)	H8.BG2
Square (0°, 135°)	H8.BG3

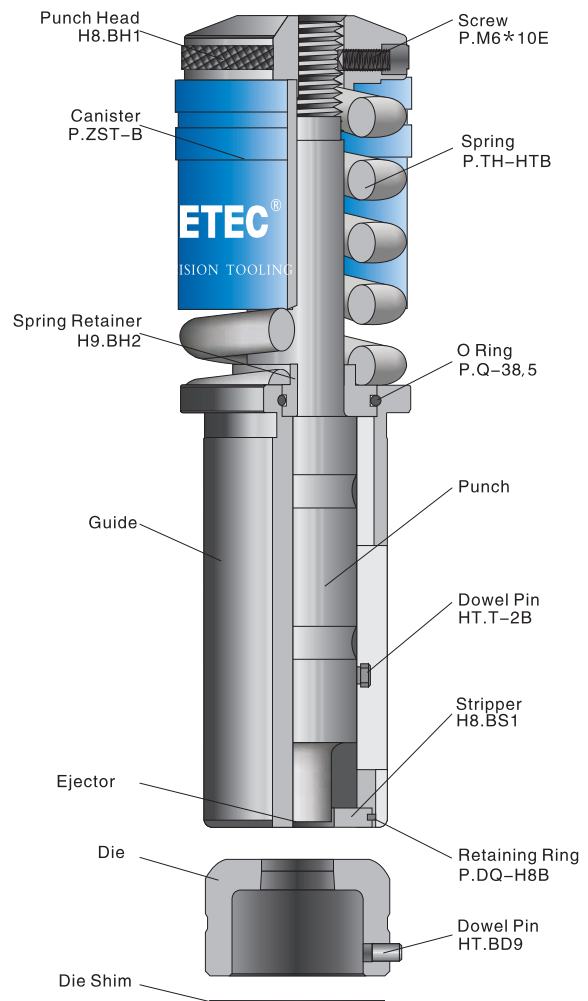



Contouring



SPH Heavy Duty



E-Break Tool  
E-Bend Tool



SPS  
Fully Guide Small Diameter



SPL

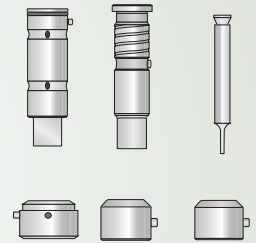

Multi-Tool



Cluster



Slitting Tool



Close To Clamp

# ■ SPECIAL TOOLING

# CONTOURING A STATION

Specification / Size:

Punch size:

Ø2mm[0.079"], Ø2.5mm[0.098"]

Die clearance:

+0.2mm [0.008"]

+0.25mm [0.010"]



## Standard

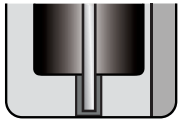

STD : 0.15MM  
[0.006"]



## SPS

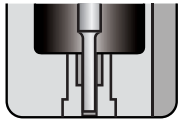

SPS: 0.025MM  
[0.0010"]



## CONTOURING

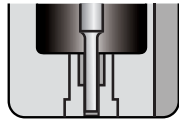

Contouring: 0.01MM  
[0.0004"]

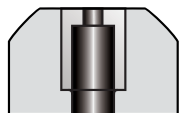

Contouring tool size:  
RO 2 + 0.2 mm [0.08"+0.008"]  
punch 1 mm [0.04"], SPCC precisely  
in 0.5mm [0.02"] step.

### Die

- Special die structure, prevent slug pulling
- Die is a Press-Fit insert structure
- Hard alloy material, hardness: HRC75, longer tool life.

### Punch

- ABS structure cools down the lubricating of slide and punch blade portion.
- Smaller size punch with changeable insert is more affordable.
- Hard alloy material, hardness: HRC75, longer tool life.
- Guide surface with hardening treatment increases wear resistance.
- Can achieve 0.5mm [0.02"] step in precisely nibbling
- Both punch and die are hard alloy material, hardness is HRC75.
- Get a fine contour with standard tools, elimination of secondary operations.
- Prevent punch breakage when disalignment
- With ABS function, reduce material adhesion to punch surface increased wear resistance, longer tool life.

Description	Code
A STN Contouring Die (Round)	HT. ADLRO
A STN Thick Turret Contouring Die (Round) $\phi 2.5+0.2$	HT. ADLRO. 2.5 /0.2
A STN Thick Turret Contouring Die (Round) $\phi 2+0.2$	HT. ADLRO. 2 /0.2
A STN Contouring Punch ass'y (Round)	HT. AALRO
A STN Thick Turret Contouring Punch ass'y (Round) $\phi 2$	HT. AALRO. 2
A STN Contouring Guide (Round)	HT. AGLRO
A STN Thick Turret Contouring Guide (Round) $\phi 2$	HT. AGLRO. 2
A STN Contouring Punch Insert (Round)	HT. APLRO
A STN Thick Turret Contouring Punch Insert (Round) $\phi 2$	HT. APLRO. 2
A STN Thick Turret Contouring Punch Insert (Round) $\phi 2.5$	HT. APLRO. 2.5

# SPS Fully Guide Small Diameter

A STATION  
(1.0–6.0mm)  
[0.23"]

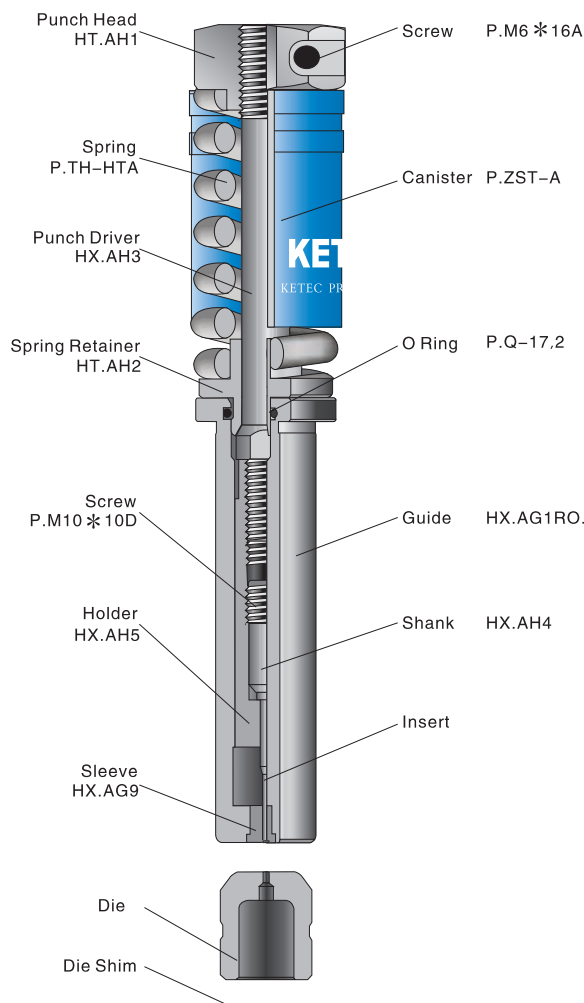

Description	Code
Punch ass'y	HX.AA1RO.
Insert	HX.AP1RO.
Guide	HX.AG1RO.
Die	HT.AD1RO.

- Recommended when punching small holes
- Replaceable insert, lower cost, only for round
- Small range: 1.0– 6 mm [0.04"~0.24"]
- Size should be over below data:

Aluminum 0.75T  
 Mild steel 1T  
 Stainless steel 2T

# SPRING PACKS LIGHT (SPL)



HL.AH9

HL.BH9

HL.CC1

HL.DC1

HL.EC1

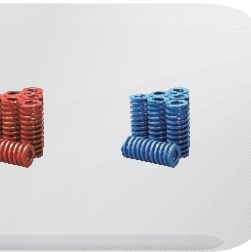
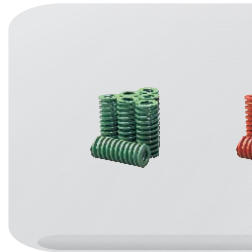

## Features:

- Eliminate or reduce unwanted sheet marking
- Compatible with STD TOP 85 series spring packs
- Adjust the numbers and sorts of springs to change the pressure of C/D/E station
- Reduce noise level, longer life for springs
- Purchase spring packs
- Suggest to use solid guide for A/B station

## Calculate pressure of springs:

- Spring pressure of A/B station compare to TOP85 series, A STN 65%, B STN 60%
- Springs with different colors should be evenly distributed when adjust the springs of C/D/E station

Spring Pressure compares to TOP 85 series, data as below form:

C STATION		D / E STATION	
Spring Combination	Percentage	Spring Combination	Percentage
9 BLUE	13%	9 BLUE	13.8%
3RED+6BLUE	17.3%	3RED+6BLUE	18%
6RED+3BLUE	21.6%	6RED+3BLUE	23%
9 RED	26%	9 RED	27.5%
6RED+3GREEN	34.6%	6RED+3GREEN	36.6%
3RED+6GREEN	43.2%	3RED+6GREEN	45.7%
9 GREEN	52%	9 GREEN	55%

■ If no special requires from buyers, the package will be 9 red and 9 green springs, buyers can adjust by themselves.

# CLOSE TO CLAMP

**D STATION**  
RE (50.81–88.9mm)  
[3-1/2"]

**E STATION**  
RE(88.91–114.3mm)  
[4-1/2"]

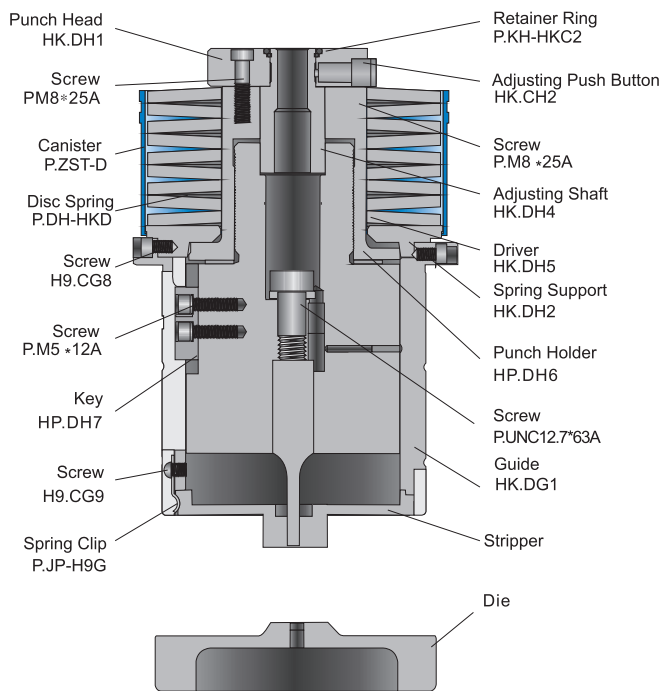

Description	Code
Punch ass'y	HR.DA1RE.
Guide ass'y	HR.DC1.
Punch Blade	HR.DP1RE.
Pin	HR.DP9
Stripper	HR.DS1RE.
Die (double)	HR.DD1RE.
Die (single)	HR.DD2RE.
Guide only	HR.DG1

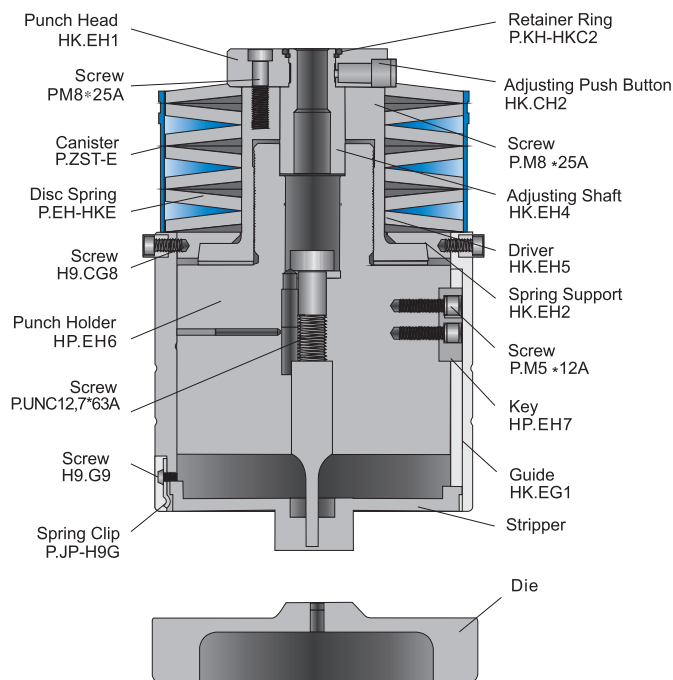

Description	Code
Punch ass'y	HR.EA1RE.
Guide ass'y	HR.EC1.
Punch Blade	HR.EP1RE.
Pin	HR.EP9
Stripper	HR.ES1RE.
Die (double)	HR.ED1RE.
Die (single)	HR.ED2RE.
Guide only	HR.EG1

# Heavy Duty (SPH80) A STATION (~12.7mm) [1/2"]



Description	Code
<b>Punch ass'y</b>	
Round (0°)	HH.AA1RO.
Square (0°, 135°)	HH.AA3SQ.
STD shape (0°, 90°)	HH.AA2**.
Other (0°, 90°)	HH.AA2**.
<b>Punch</b>	
Round (no pin)	HH.AP1RO.
STD shape (pin)	HH.AP2**.
Other (pin)	HH.AP2**.
<b>Stripper</b>	
Round	H9.AS1RO.
STD shape	H9.AS1**.
Other	H9.AS1**.
<b>Die</b>	
Round (no pin)	HZ.AD1RO.
STD shape (pin)	HZ.AD2**.
Other (pin)	HZ.AD2**.
<b>Guide</b>	
Round (0°)	H9.AG1
Shape (0°, 90°)	H9.AG2
Square (0°, 135°)	H9.AG3

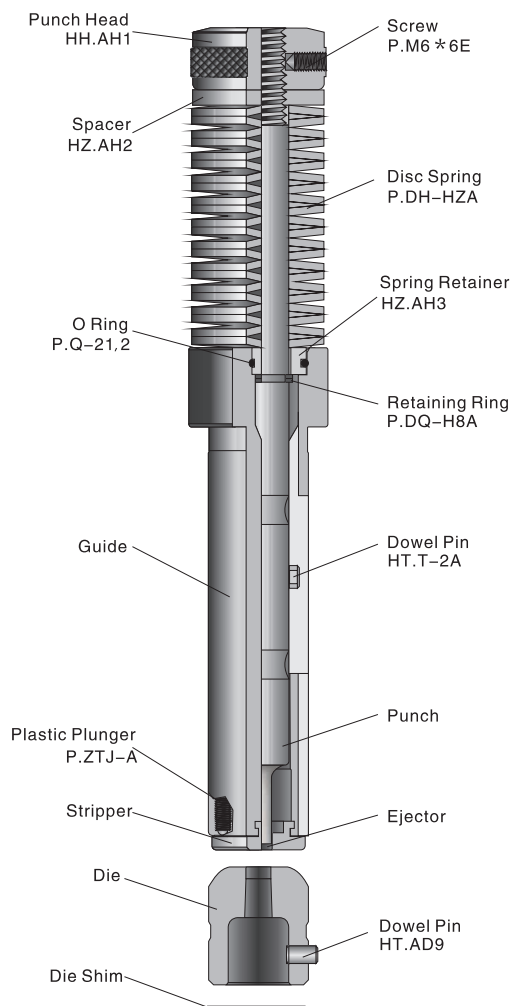



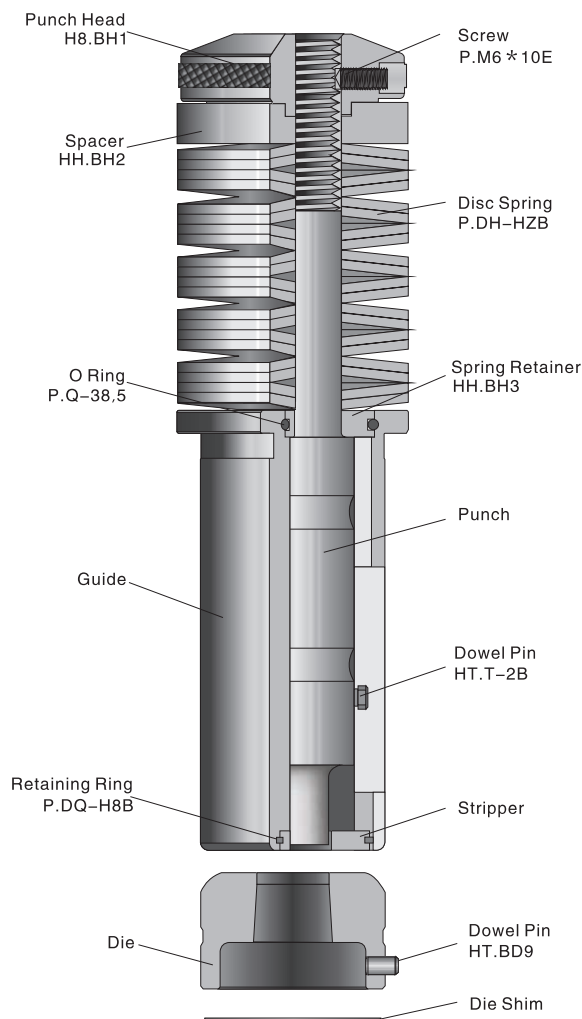





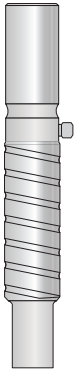
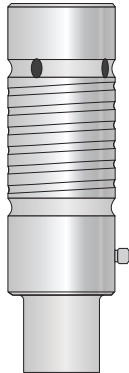
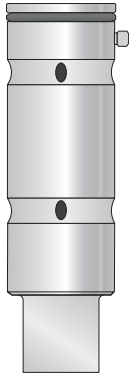
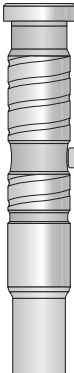
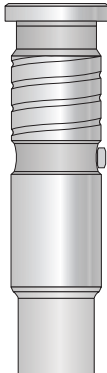





# Heavy Duty (SPH80) B STATION (12.71–31.7mm) [1-1/4"]

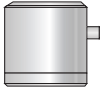

Description	Code
<b>Punch ass'y</b>	
Round (0°)	HH.BA1RO.
Square (0°, 135°)	HH.BA3SQ.
STD shape (0°, 90°)	HH.BA2**.
Other (0°, 90°)	HH.BA2**.
<b>Punch</b>	
Round (no pin)	HH.BP1RO.
STD shape (pin)	HH.BP2**.
Other (pin)	HH.BP2**.
<b>Stripper</b>	
Round	H8.BS1RO.
STD shape	H8.BS1**.
Other	H8.BS1**.
<b>Die</b>	
Round (no pin)	HZ.BD1RO.
STD shape (pin)	HZ.BD2**.
Other (pin)	HZ.BD2**.
<b>Guide</b>	
Round (0°)	H8.BG1
Shape (0°, 90°)	H8.BG2
Square (0°, 135°)	H8.BG3

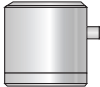
# MULTI-TOOL

	MTHUA	MTHUB	MTHGB	XMT12.7mm	XMT24mm
Punch Round Shape Square	HU.AP1RO. HU.AP1**. HU.AP1.	HU.BP1RO. HU.BP1**. HU.BP1.	HG.BP1RO. HG.BP2**. HG.BP2.	HE.10P1. HE.10P2**. HE.10P2**.	HE.6P1. HE.6P2**.
					
Stripper					
Round Shape Square	HU.AS1RO. HU.AS1**. HU.AS1.	HU.BS1RO. HU.BS1**. HU.BS1.	H9.BS1RO. H9.BS2**. H9.BS3.	HE.10S1. HE.10S1**. HE.10S1.	HE.6S1. HE.6S1**. HE.6S1.
Die					
Round Shape Square	HT.AD1RO. HT.AD2**. HT.AD2.	HT.BD1RO. HT.BD2**. HT.BD2.	HW.3D1RO. HW.3D2**. HW.3D2.	HE.10D1. HE.10D2**. HE.10D2.	HF.8D1. HF.8D2**. HF.8D3.
					
	HT.AD1RO. HT.AD2**. HT.AD2.	HT.BD1RO. HT.BD2**. HT.BD2.	HW.3D1RO. HW.3D2**. HW.3D2.	HE.10D1. HE.10D2**. HE.10D2.	HF.8D1. HF.8D2**. HF.8D3.
	MTHUA	MTHUB	MTHGB	XMT12.7mm	XMT24mm
Max. Size of Punch	12.7mm	31.7mm	31.7mm	12.7.0mm	24.0mm
Max. Size of Die	12.7mm+1.5mm	12.7mm+1.5mm	12.7mm+1.5mm	12.7mm+1.5mm	24.0mm+1.5mm
Height of Punch	108mm	100.5mm	100.5mm	100.0mm	100.0mm
Height of Die	30.0mm	30.0mm	15.0mm	17.5mm	24.0mm
Suitable for	Ultra MT8 Ultra IMT8	Ultra MT3 Ultra IMT3 MTE4-31.75mm	MT3Ri	XMTE10	XMTE6,XMTE10

DMT24mm

MT24-8mm

MT10-16mm

MT8-24mm

MT8i1-16mm

MT8i2-16mm

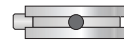
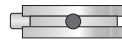
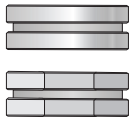
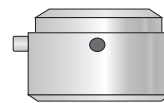
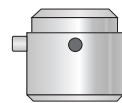
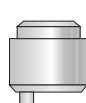
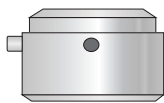
Q.H.0013.RO  
Q.H.0013.\*\*HF.24P1.  
HF. 24P1\*\*HF.10P1.  
HF. 10P1\*\*HF.8P1.  
HF. 8P1\*\*HW.8P1.RO  
HW.8P2\*\*  
HW.8P3SQHW.8P1.RO  
HW.8P2\*\*  
HW.8P3SQQ.H.0014.RO  
Q.H.0015.\*\*  
Q.H.0015.SQ.HF.24S1.  
HF.24S2\*\*  
HF.24S2.HF.10S1.  
HF.10S2\*\*  
HF.10S3.HF.8S1.  
HF.8S2\*\*  
HF.8S3.HW.8S1.  
HW.8S1\*\*  
HW.8S1.HW.8S1.  
HW.8S1\*\*  
HW.8S1.HF.8D1.  
HF.8D2\*\*  
HF.8D3.HF.24D1.  
HF.24D2\*\*  
HF.24D2.HF.10D1.  
HF.10D2\*\*  
HF.10D3.HF.8D1.  
HF.8D2\*\*  
HF.8D3.HW.8D1.  
HW.8D2\*\*  
HW.8D2.HW.8D1.  
HW.8D2\*\*  
HW.8D2.

DMT24mm

MT24-8mm

MT10-16mm

MT8-24mm

MT8i1-16mm

MT8i2-16mm

24.0mm

8.0mm

16.0mm

24.0mm

16.0mm

16.0mm

24.0mm+1.5mm

8.0mm+1.5mm

16.0mm+1.5mm

24.0mm+1.5mm

16.0mm+1.5mm

16.0mm+1.5mm

113.5mm

70.5mm

70.5mm

70.5mm

100.0mm

100.6mm

24.0mm

17.0mm

24.0mm

24.0mm

17.6mm

17.6mm

only for DURMA

MT20,MT24,  
MT12,MT20,

MT6,MT10

MT6,MT8  
MTE6,MTE10

MT8Ri

MT8Ri

# E-Break Tool E-Bend Tool



## E-Break tool

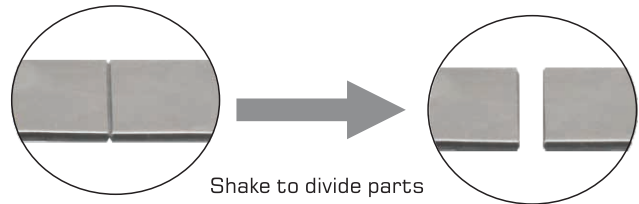

## E-Bend tool

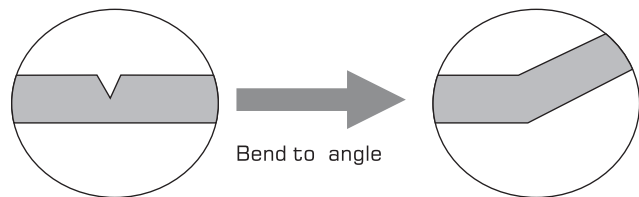

### The code of E-Break tool

	Punch ass'y	Die ass'y
<b>B STN</b>	H.TBX.DZ**	H.TBS.DZ**
<b>C STN</b>	H.TCX.DZ**	H.TCS.DZ**

### The code of E-Bend Tool

	Set ass'y	Set ass'y
<b>B STN</b>	H.TBS.DZ**	H.TBX.DZ**
<b>C STN</b>	H.TCS.DZ**	H.TCX.DZ**

- Be available at B, C, D station.
- Punch ass'y designed for specified thickness and material. Not adjust.
- V-line tip on punch and die insert create weak slot in sheet metal. Shake up and down to break parts. In E-bend, only one V-line tip.
- Restriction for thickness: Minimum 0.8mm[0.03"], Maximum 1.5mm[0.06"]
- E-Break tool, clear, smooth in cutting edge after breaking.
- E-Bend tool, the angle is not recommended to be over 90 degree.

# SLITTING TOOL



	Description	C STN	D STN	E STN	WIDTH
Wilson	Blade	HI.CW1RE	HI.DW1RE	HI.EW1RE	19.05mm [0.77"]
	Holder	HI.CW9			19.05mm
Amada	Blade		HI.DT1RE	HI.ET1RE	16mm [0.63"]
	Holder		HI.DT9	HI.ET9	16mm
	ABS Holder		HI.DT8	HI.ET8	16mm
Mate	Blade		HI.DM1RE	HI.EM1RE	18mm [0.71"]
	Holder		HI.DM9		18mm

# CLUSTER

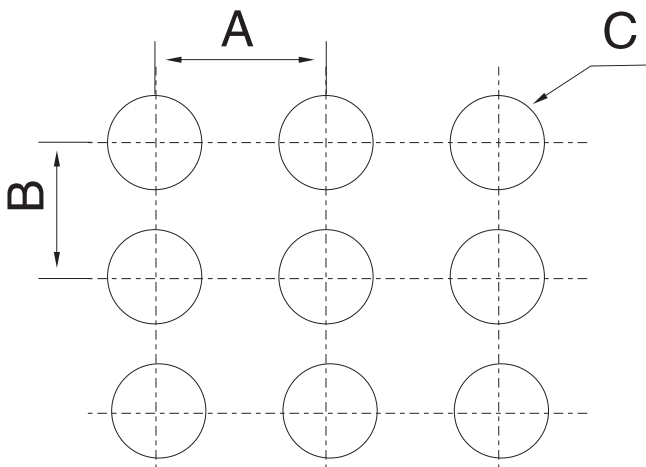

Machine \_\_\_\_\_ A \_\_\_\_\_  
 Material \_\_\_\_\_ B \_\_\_\_\_  
 C \_\_\_\_\_ T \_\_\_\_\_

- Space of holes must be over 3.2mm [0.13"] or 2T
- Please fill in the above form



## ■ FORMING TOOLS

KETEC have extensive experience in the design and manufacture of the forming tools, we also have TRUMPF machine, thick turret CNC machine etc., for testing the tooling. We surely can provide the ideal tooling products to you.

Please consult KETEC engineers for questions when customizing the forming tools to your design.

# Q-ADJUST FORMING TOOL A/B STATION

The first time for testing a forming tool, which requires continuously adjusting the length for the tool, until the workpiece meets the requirements. In this process, the old structure spring pack, needs to be removed from the CNC punch machine, loosened the screw to adjust, measured the length, locked the screw and put back to the CNC punch machine for testing again and again. This operation is generally carried out many times, lots of works and low efficiency.

By improving the structure of the main parts, Q-Adjust forming tool can achieve a fast and accurate adjustment on the length of the tools. simplify the assembly and disassembly, reduce the labor intensity and reliance on the tools, improve the productivity.

## Adjust the length of A STN:

- Push the side button on the punch head and turn clockwise, decreases the length of the tool;
- Push the side button on the punch head and turn anti-clockwise, increases the length of the tool;
- Loose the side button, the punch head is locked;
- The circle of the punch head is divided into several sections for turning, the variation for each click is 0.05mm [0.002"], can achieve a precise adjustment.

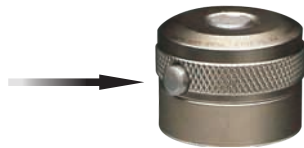
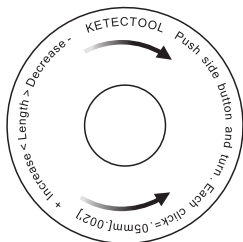

## Adjust the length of B STN:

- Push the side button on the punch head and turn clockwise, decreases the length of the tool;
- Push the side button on the punch head and turn anti-clockwise, increases the length of the tool;
- Loose the side button, the punch head is locked;
- The circle of the punch head is divided into several sections for turning, the variation for each click is 0.075mm [0.003"], can achieve a precise adjustment.

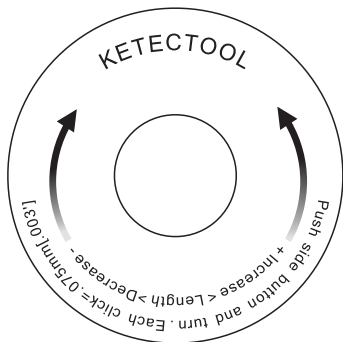

# Q-ADJUST FORMING TOOL C/D STATION



## Adjust the length of C/D STN:

- Loosen the screw nut in figure I, turn the punch head in clockwise way, decreases the length of the tool;
- Turn the punch head in anti-clockwise way, increases the length of the tool, when the length is meets the measurement, lock the screw nut.
- Punch head is divided into coarse thread and fine thread, depending on the specific requirements of the forming tool;
- The circle of the punch head is divided into several sections for turning
  - the variation: for fine thread, each click is 0.06mm [0.0024"] (figure II)
  - the variation: for coarse thread, each click is 0.13mm [0.0051"] (figure III)
- All tools from KETEC are clearly identified the direction and amount of the adjustment (as the figures below).
- Make sure all the tools can be precise and quick adjusted.

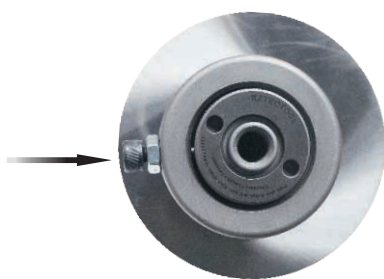

figure I

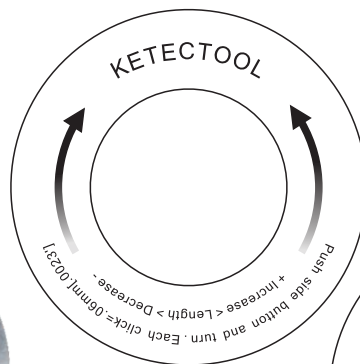

figure II

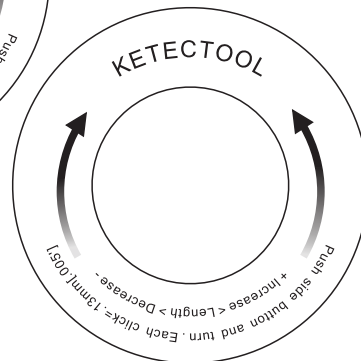

figure III

# WHEEL RIB

- High speed, equal to table travel speed
- Make any shape in auto index station
- No nibble marks
- Replaceable wheels
- Works under related program
- Thickness:
  - Stainless steel 0.8–1.5mm [0.03"~0.06"]
  - Mild steel 0.8–2mm [0.03"~0.08"]
  - Aluminum 0.8–2.5mm [0.03"~0.10"]
- Height: 2~3T, Width: 4~6T(2\*H), Max Width: 12.7mm [0.50"]



# WHEEL OFFSET

- High speed, equal to table travel speed
- Make any shape in auto index station
- No nibble marks
- Replaceable wheels
- Works under related program
- Thickness:
  - Stainless steel 0.8–1.5mm [0.03"~0.06"]
  - Mild steel 0.8–2mm [0.03"~0.08"]
  - Aluminum 0.8–2.5mm [0.03"~0.10"]



# CHARACTER STAMPING

Character font & range:

A B C D E F G H I J K L M

N O P Q R S T U V W X Y Z

0 1 2 3 4 5 6 7 8 9

& / . - ( )

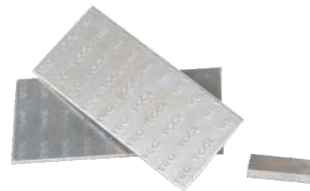
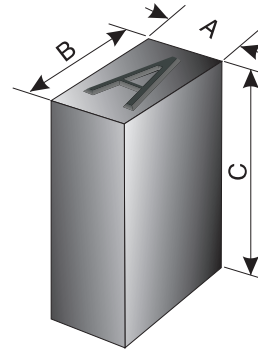

Character type & size:

TYPE	SIZE A	SIZE B	SIZE C
2.4	2.36mm [0.09"]	6.35mm [0.25"]	19.05mm [0.75"]
3.2	3.175mm [0.13"]	6.35mm [0.25"]	19.05mm [0.75"]
4.8	4.76mm [0.19"]	7.94mm [0.31"]	19.05mm [0.75"]
6.4	6.35mm [0.25"]	9.52mm [0.37"]	19.05mm [0.75"]

Note: 2.4 type is too small, not recommended.

Character height chart (1:1)

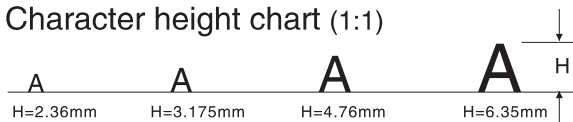

Character depth & force KN (AL, MS, SS)

TYPE	DEPTH	AL	MS	SS
2.4	0.1mm	1.1KN	2.8KN	8.9KN
3.2	0.1mm	1.6KN	4.4KN	13.3KN
4.8	0.2mm	3.6KN	10.7KN	30.2KN
6.4	0.3mm	6.2KN	16.9KN	48.9KN

Note: 2.4 type is too small, not recommended.



# EMBOSS-EXPANDED METAL

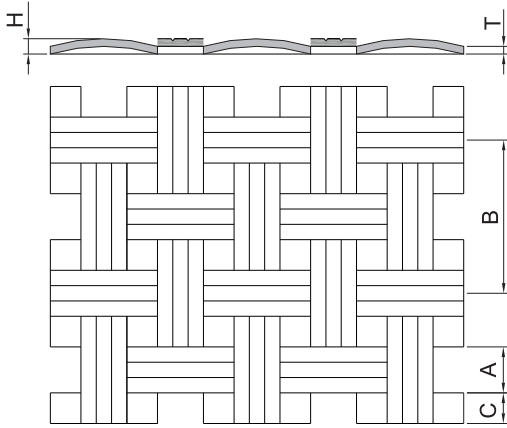

Machine \_\_\_\_\_ A \_\_\_\_\_  
 Material \_\_\_\_\_ B \_\_\_\_\_ H \_\_\_\_\_  
 \_\_\_\_\_ C \_\_\_\_\_ T \_\_\_\_\_

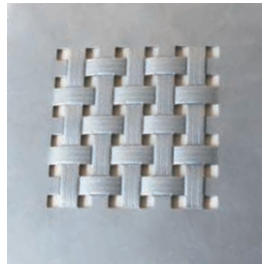

- Forbid punching without sheet
- Need prepunch
- Max. thickness: mild steel 1.5mm [0.06"]
- Fill in the above form

# EMBOSS-DRIPS

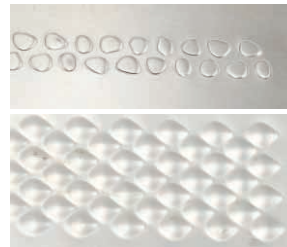
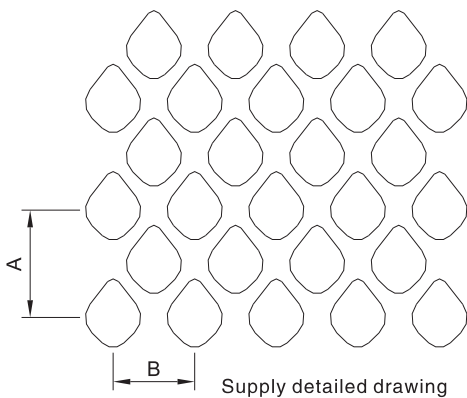
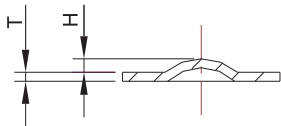

Machine \_\_\_\_\_ A \_\_\_\_\_ H \_\_\_\_\_  
 Material \_\_\_\_\_ B \_\_\_\_\_ T \_\_\_\_\_

- Forbid punching without sheet
- Max. thickness: 1.5mm [0.06"]
- Fill in the above form

# CENTERPOINT

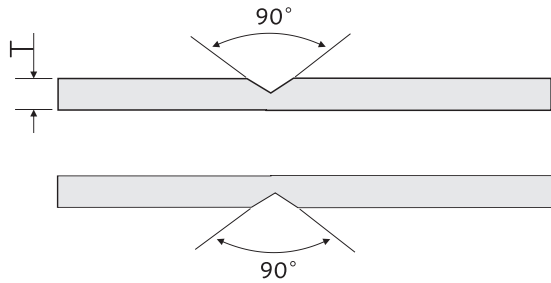

Form Down

Form Up



- Forbid punching without sheet
- Adjust punch ass'y height to control the depth of centerpoint
- Form Up, Form Down
- Angle: 90°, Max. thickness: 6.0mm [0.24"]

Machine \_\_\_\_\_  
Material \_\_\_\_\_ T \_\_\_\_\_

# HALF SHEAR

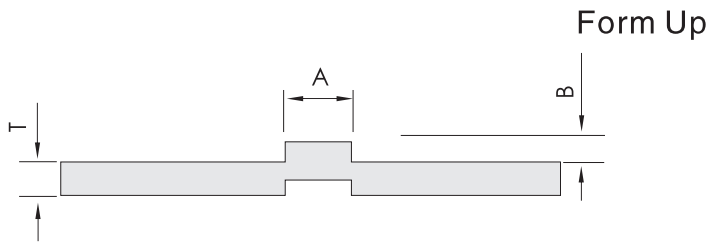

Form Up

Machine \_\_\_\_\_ A \_\_\_\_\_  
Material \_\_\_\_\_ B \_\_\_\_\_ T \_\_\_\_\_

- Give tool enough time to strip
- Form Up, Form Down
- Max. B size: 0.6T



# EXTRUSION TAPPING

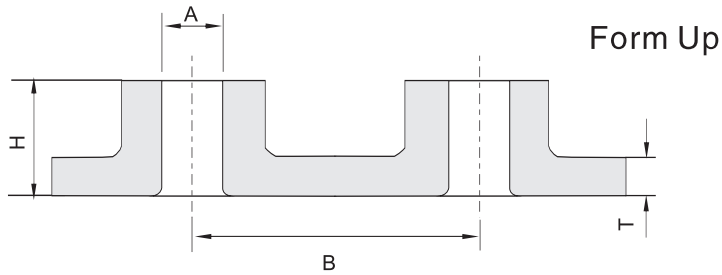

Machine \_\_\_\_\_ A \_\_\_\_\_  
 Material \_\_\_\_\_ B \_\_\_\_\_ T \_\_\_\_\_  
 H \_\_\_\_\_

- Need prepunch
- Give tool enough time to strip
- Replaceable insert design on extrusion
- Form Up, Form Down
- Max. thickness: Mild steel 2.3mm [0.09"], AL 2.0mm [0.08"], 1.2mm [0.05"]
- Forming height (Max. H): over 3\*thread pitch

Prepunch size (Stainless steel) Unit: mm [inch]

Extrusion Size	ØA	Thickness: T			
		0.6 [0.02"]	0.8 [0.03"]	1.0 [0.04"]	1.2 [0.05"]
M2.6	2.21 [0.09"]	1.3 [0.05"]	1.3	1.3	
M3	2.60 [0.10"]	1.3	1.3	1.6 [0.06"]	1.8 [0.07"]
M4	3.40 [0.13"]		2.0 [0.08"]	2.0	2.0
M5	4.30 [0.17"]			2.3 [0.09"]	2.3
M6	5.10 [0.20"]			3.0 [0.12"]	3.0

Prepunch Size (MS, AL) Unit: mm [inch]

Extrusion Size	ØA	Thickness: T					
		0.8 [0.03"]	1.0 [0.04"]	1.2 [0.05"]	1.6 [0.06"]	2.0 [0.08"]	2.3 (no AL) [0.09"]
M2.6	2.21 [0.09"]	1.3 [0.05"]	1.3	1.3	1.6 [0.06"]		
M3	2.60 [0.10"]	1.3	1.3	1.6	1.6		
M4	3.40 [0.13"]	2.0 [0.08"]	2.0	2.0	2.3	2.3	2.5 [0.10"]
M5	4.30 [0.17"]		2.3 [0.09"]	2.3	2.8 [0.11"]	2.8	3.0
M6	5.10 [0.20"]			3.0 [0.12"]	3.0	3.8 [0.15"]	3.8



# EXTRUSION

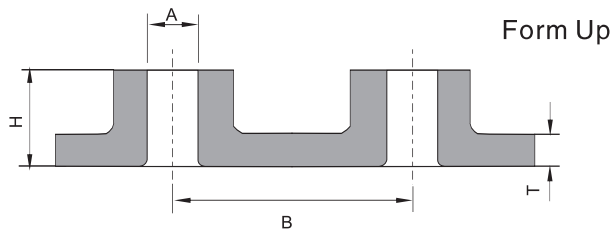

Machine \_\_\_\_\_  
 Material \_\_\_\_\_

A \_\_\_\_\_  
 B \_\_\_\_\_  
 H \_\_\_\_\_  
 T \_\_\_\_\_

- Need prepunch
- Give tool enough time to strip
- Form Up, Form Down
- Max. height:  $H \geq 2T$



# EMBOSS & EXTRUSION

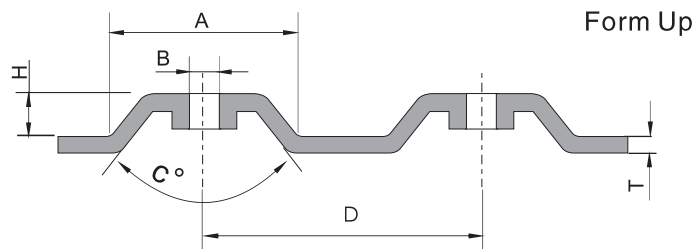

Machine \_\_\_\_\_  
 Material \_\_\_\_\_

A \_\_\_\_\_  
 B \_\_\_\_\_  
 C \_\_\_\_\_  
 D \_\_\_\_\_  
 H \_\_\_\_\_  
 T \_\_\_\_\_

- Complete emboss and extrusion on one hit
- Give tool enough time to strip
- Form Up only



# EMBOSS

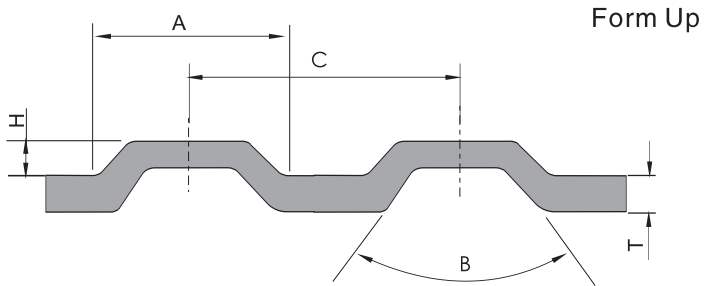

Machine \_\_\_\_\_ A \_\_\_\_\_ H \_\_\_\_\_  
 Material \_\_\_\_\_ B \_\_\_\_\_ C \_\_\_\_\_ T \_\_\_\_\_

- Escape clamp or punching hole
- Can form in Round or Shape
- Give tool enough time to strip
- Form Up, Form Down



# BRIDGE

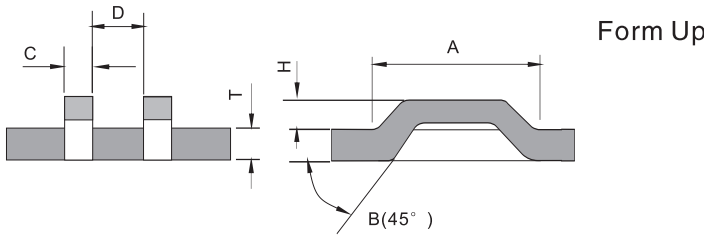

Machine \_\_\_\_\_ A \_\_\_\_\_ D \_\_\_\_\_  
 Material \_\_\_\_\_ B \_\_\_\_\_ C \_\_\_\_\_ H \_\_\_\_\_ T \_\_\_\_\_

- Can be designed in single or double bridge
- Give tool enough time to strip
- Form Up, Form Down
- Width of the Bridge:  $C \geq 2T$  and  $C \geq 1.8\text{mm}$  [0.07"]



# LANCE & FORM

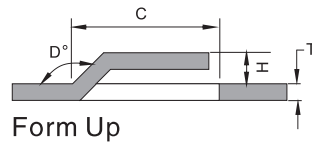
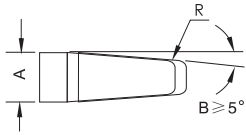

Machine \_\_\_\_\_  
 Material \_\_\_\_\_  
 A: \_\_\_\_\_ D: \_\_\_\_\_  
 B: \_\_\_\_\_ R: \_\_\_\_\_  
 C: \_\_\_\_\_ H: \_\_\_\_\_ T: \_\_\_\_\_

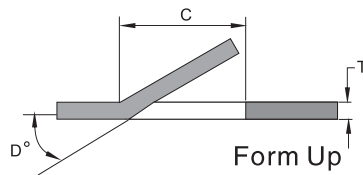
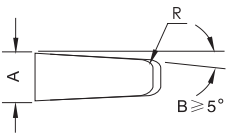

Machine \_\_\_\_\_  
 Material \_\_\_\_\_  
 A \_\_\_\_\_  
 B \_\_\_\_\_ D \_\_\_\_\_  
 C \_\_\_\_\_ R \_\_\_\_\_ T \_\_\_\_\_



- Tooling is made for specific thickness
- Give tool enough time to strip
- Form up only

# LOCATOR

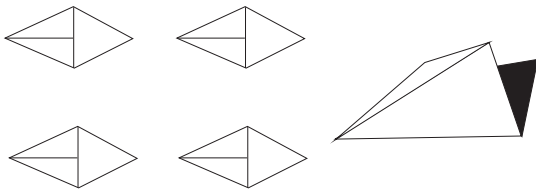

- No scrab on opposite side of sheet metal
- Use thinner thickness if shear button cannot work
- Forbid punching without sheet
- Min. spaces between centers of locators: 15mm

# CLOSE LOUVER

STOCKED SIZE				
SIZE A	50 [1.97]	80 [3.15]	80 [3.15]	80 [3.15]
SIZE B	10 [0.39]	10 [0.39]	12 [0.47]	15 [0.59]
SIZE H	5 [0.20]	6 [0.24]	6 [0.24]	6 [0.24]

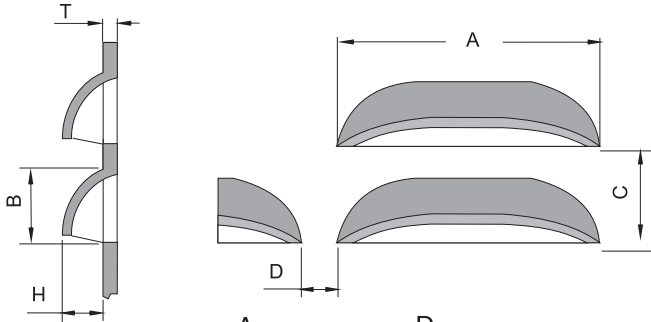

Machine \_\_\_\_\_  
 Material \_\_\_\_\_

A \_\_\_\_\_ D \_\_\_\_\_  
 B \_\_\_\_\_ H \_\_\_\_\_  
 C \_\_\_\_\_ T \_\_\_\_\_



- Tooling is made for specific thickness
- Consider the travel direction of the sheet metal, give tool enough time to strip
- Adjust length without shim, replaceable insert
- Form Up only

# OPEN LOUVER

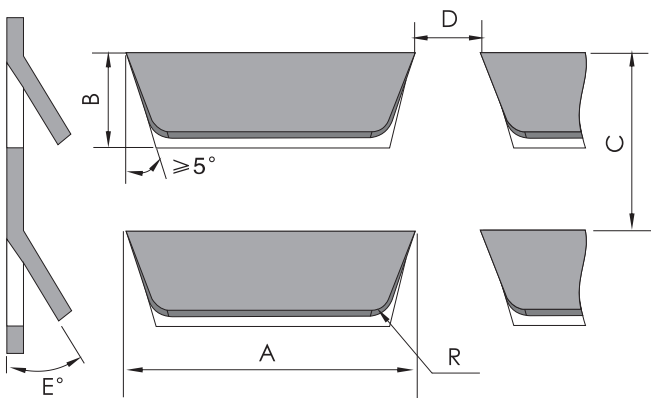

Machine \_\_\_\_\_  
 Material \_\_\_\_\_

A \_\_\_\_\_ D \_\_\_\_\_  
 B \_\_\_\_\_ E \_\_\_\_\_  
 C \_\_\_\_\_ T \_\_\_\_\_ R \_\_\_\_\_



- Tooling is made for specific thickness
- Consider the travel direction of the sheet metal, give tool enough time to strip
- Adjust length without shim, replaceable insert
- Form Up only

# CARD GUIDE

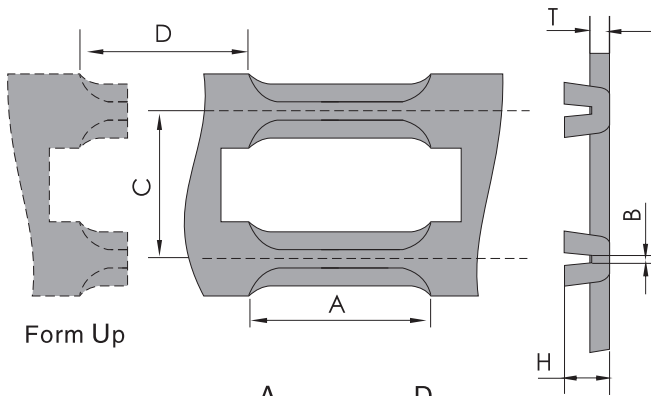

Machine \_\_\_\_\_ A \_\_\_\_\_ D \_\_\_\_\_  
 Material \_\_\_\_\_ B \_\_\_\_\_ H \_\_\_\_\_  
 C \_\_\_\_\_ T \_\_\_\_\_



- Tooling is made for specific thickness
- Give tool enough time to strip
- Adjust length without shim, replaceable insert
- Form up Height:  $H \leq 2T$ , otherwise will be deformation easily
- Form Up

# HINGE

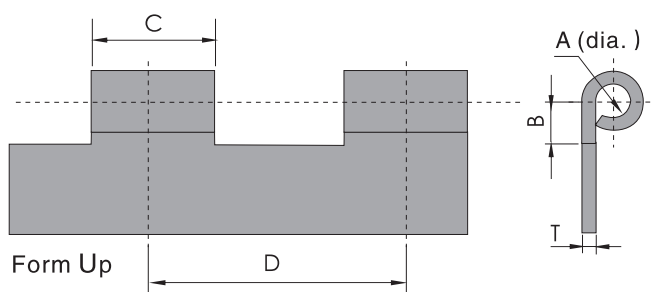

Machine \_\_\_\_\_ A \_\_\_\_\_ D \_\_\_\_\_  
 Material \_\_\_\_\_ B \_\_\_\_\_ T \_\_\_\_\_  
 C \_\_\_\_\_



- Tooling is made for specific thickness, need prepunch
- First for curling, second for forming
- Thickness:  $T \leq 1.5\text{mm}$  (Mild Steel);  $T \leq 1.5\text{mm}$  (Stainless Steel)
- Form Up only

# RIB TOOL

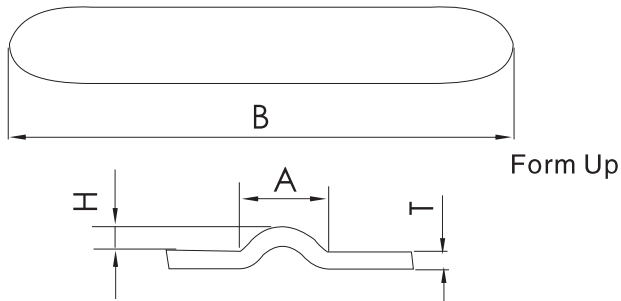

Machine \_\_\_\_\_ A \_\_\_\_\_ H \_\_\_\_\_  
 Material \_\_\_\_\_ B \_\_\_\_\_ T \_\_\_\_\_

- Keep proper away from holes, clamp, material edge
- Form Up, Form Down
- Increment of ribbing rib should be 0.5~2.0mm [0.02"~0.08"]
- Max. thickness 2.7mm (MS & AL), 2.3mm(SS)

# KNOCKOUT

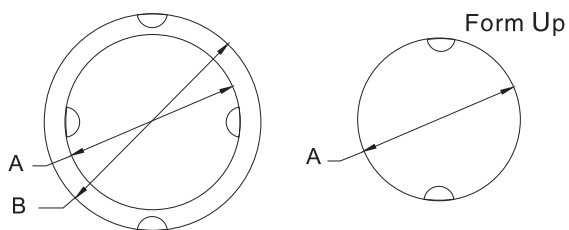

Machine \_\_\_\_\_ A \_\_\_\_\_ T \_\_\_\_\_  
 Material \_\_\_\_\_ B \_\_\_\_\_

- Forbid punching without sheet
- Adjust the height of the tool to change the depth when punching
- Can be designed in single / double / triple EKO
- The positioning must be accurated for the bottom dead point of the CNC punch press machine
- Form Up, Form Down

# THREAD FORM

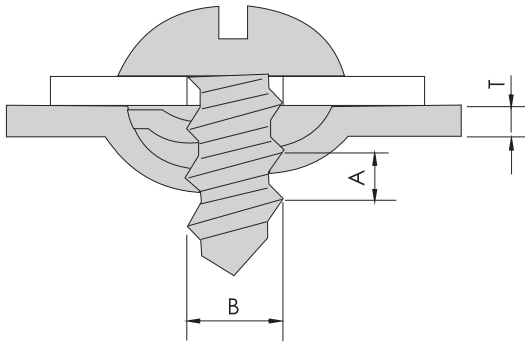

Machine \_\_\_\_\_ A \_\_\_\_\_  
 Material \_\_\_\_\_ B \_\_\_\_\_ T \_\_\_\_\_

- Form Up, Form Down
- Thickness range: 0.5mm~1.2mm [0.02"~0.05"]



# THREAD LOOP

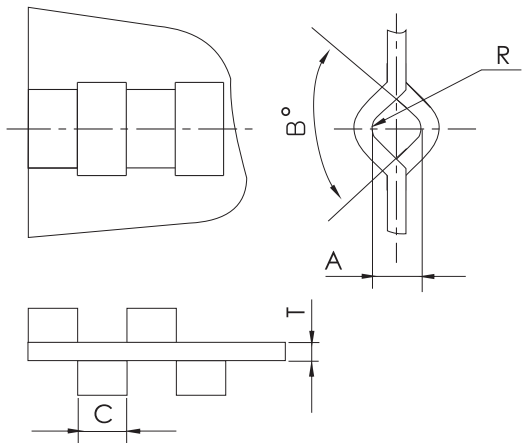

Machine \_\_\_\_\_ A \_\_\_\_\_ C \_\_\_\_\_ R \_\_\_\_\_  
 Material \_\_\_\_\_ B \_\_\_\_\_ T \_\_\_\_\_

- Standard angle for B is 90°
- Please fill in the left form



# STAMPING

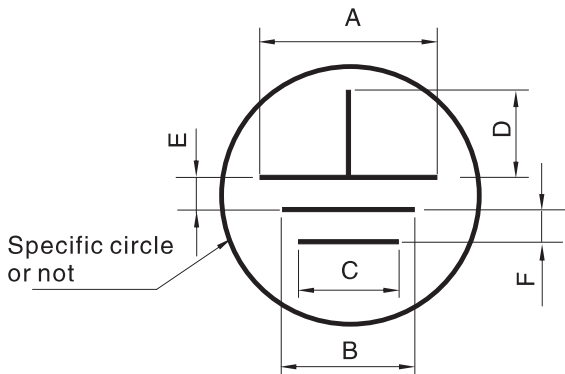

Machine \_\_\_\_\_ A \_\_\_\_\_ D \_\_\_\_\_ G<sub>(width)</sub> \_\_\_\_\_  
 Material \_\_\_\_\_ B \_\_\_\_\_ E \_\_\_\_\_ H<sub>(depth)</sub> \_\_\_\_\_  
 C \_\_\_\_\_ F \_\_\_\_\_

- Forbid punching without sheet
- Adjust the height of the tool to change the depth when punching
- Turn in any direction in auto index station
- Form Up, Form Down



# MULTI-SCRIBE



- Forbid punching without sheet
- Required special control program for the machine
- Change spring for different sheet metal in auto index station
- Form Down only

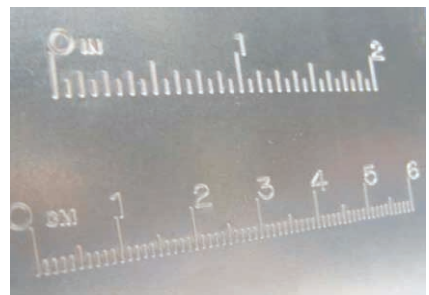

# COUNTERSINK

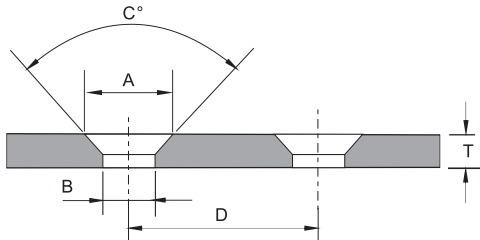

Machine \_\_\_\_\_  
Material \_\_\_\_\_

A \_\_\_\_\_  
B \_\_\_\_\_  
C \_\_\_\_\_  
D \_\_\_\_\_  
T \_\_\_\_\_

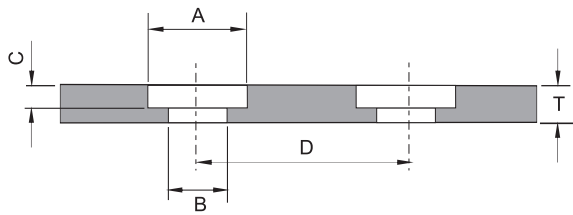

Machine \_\_\_\_\_  
Material \_\_\_\_\_

A \_\_\_\_\_  
B \_\_\_\_\_  
C \_\_\_\_\_  
D \_\_\_\_\_  
T \_\_\_\_\_

- Need prepunch
- Adjust prepunch size to get different depth
- Form Up, Form Down
- Max. thickness:  $T \geq 1.0\text{mm}$  [0.04"]

# EMBOSS COUNTERSINK

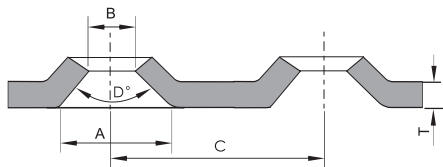

Machine \_\_\_\_\_  
Material \_\_\_\_\_

A \_\_\_\_\_  
B \_\_\_\_\_  
C \_\_\_\_\_  
D \_\_\_\_\_  
T \_\_\_\_\_

- Suggest using prepunch
- Form up only



Thick Turret Tools Cabinet



Thick Turret Tools Trolley



Demagnetizer



Visual Measurement System for Sheet Metal



Auto Tool Grinding Machine



## SHEET METAL ACCESSORIES

- Visual Measurement System for Sheet Metal
- Thick Turret Tools Cabinet
- Thick Turret Tools Trolley
- Alignment Tool
- Adaptor
- Demagnetizer
- Mounting or Dismounting Holder
- Accessories
- Auto Tool Grinding Machine

# VISUAL MEASUREMENT SYSTEM FOR SHEET METAL



Suitable for measuring the flat sheet metal of CNC punching machine, laser cutting machine, plasma cutting machine, general punching machine.

- Measurement accuracy: central area  $\pm 0.05\text{mm}$  [0.002"]
- Single max. measurement range: 1500mm  $\times$  1000mm [59.05"  $\times$  39.37"]
- Applicable range: flat sheet metal parts of different materials
- Size: 2090mm(L)  $\times$  1880mm(W)  $\times$  3700mm(H) [82.28"(L)  $\times$  74.01"(W)  $\times$  145.67"(H) ]
- Weight: approx. 800Kg
- Power supply: single-phase AC 220V
- Power: < 1.5KW

# Thick Turret Tools Trolley

Code: J.MJC-HT

## Standard configuration

6 Shelves (3A+3B), 12 Shelf supports  
Full load 27 sets A station,  
18 sets B station,  
several C/D/E station



Shelf for A station J.MJC-HTMJ1

Capacity: Each shelf 9 sets Punch ass'y



Shelf for B station J.MJC-HTMJ2

Capacity: Each shelf 6 sets Punch ass'y

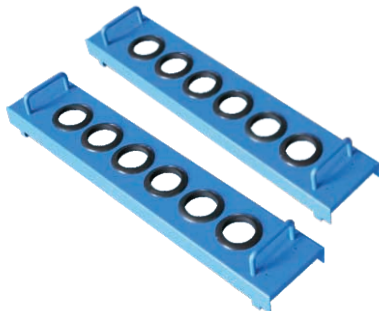

# Thick Turret Tools Cabinet

Code: J.MJG-HT

Standard configuration

Accommodates 4 Layers (Standard: 2A+2B)

A STN Punch ass'y 36 sets, Punch 36 pcs, Die 110 pcs

B STN Punch ass'y 24 sets, Punch 24 pcs, Die 80 pcs

Features C/D/E STN Punch ass'y 12 sets, several Punches, Dies, Strippers

Layer for A STN J.MJG-HTCB1  
Capacity:  
Each layer loads 18 punch ass'y, 18 punches  
and 54 dies

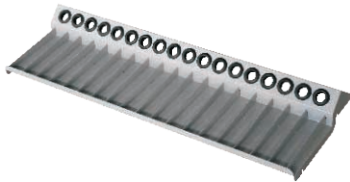

Thick Turret Tools Cabinet  
J.MJG-HTGT

Layer for B STN J.MJG-HTCB2  
Capacity:  
Each layer loads 12 punch ass'y, 12 punches  
and 36 dies

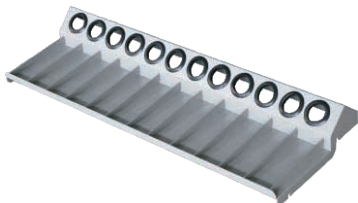

# ALIGNMENT TOOL



A STN



B STN



C STN



D STN

DESCRIPTION	Code	Code	Code	Code
Set assy	J.DW-HA1	J.DW-HB1	J.DW-HC1	J.DW-HD1
Punch assy	J.DW-HA2	J.DW-HB2	J.DW-HC2	J.DW-HD2
Die	J.DW-HA3	J.DW-HB3	J.DW-HC3	J.DW-HD3
T-Handle	J.DW-HA4	J.DW-HB4	J.DW-HB4	J.DW-HB4

# ADAPTER



B-A



C-A



C-B



D-B

STN	Description	Code	Price
B-A	Punch ass'y	J.H-BA1	
	Die ass'y	J.H-BA3	
C-A	Punch ass'y	J.H-CA1	
	Die ass'y	J.H-CA3	
D-A	Punch ass'y	J.H-DA1	
	Die ass'y	J.H-DA3	
C-B	Punch ass'y	J.H-CB1	
	Die ass'y	J.H-CB3	
D-B	Punch ass'y	J.H-DB1	
	Die ass'y	J.H-DB3	
D-C	Punch ass'y Die ass'y	J.H-DC1	

# DEMAGNITIZER

CODE	PRICE
J.DZ-1	



Technical data:

1. Rated voltage: 220V ± 10% 50HZ
2. Rated current: 3.3A single phase
3. Electrical energy: 1KW, Weight 6.0 KG
4. Size(mm): 300x158x230 [11.81"x6.22"x9.05"]

# MOUNTING & DISMOUNTING HOLDER



Description	Code	Price
Holder for set	J.ZPT	
Holder for A/B punch	J.ZPT-HAB	
Holder for A/B forming	J.ZPT-HABS	
Holder for C/D/E	J.ZPT-HCDE	

# BALL RIDING DIE BRUSH DIE

Ball Riding Die		
STN	CODE	PRICE
A station	J.GZ-HA1	
B station	J.GZ-HB1	
C station	J.GZ-HC1	
D station	J.GZ-HD1	



Brush Die		
STN	CODE	PRICE
A station	J.MS-HA1	
B station	J.MS-HB1	
C station	J.MS-HC1	
D station	J.MS-HD1	

# ACCESSORIES

Inner Plier		Outer Plier	
Code	Price	Code	Price
J.NKQ		J.WKQ	



Hex Wrench	
Code	Price
J.BS	



# EJECTOR

Description	φ 3mm		φ 6mm		φ 10mm	
	Code	Price	Code	Price	Code	Price
Ejector	P.JL03		P.JL06		P.JL10	
Package	P.JL0315		P.JL0610		P.JL1005	



# SHIM



Description	A STN	B STN	C STN	D STN
	Code	Code	Code	Code
Punch Shim 0.4mm 0.016"			P.DP-HCP04	P.DP-HDP04
Punch Shim 0.8mm 0.031"			P.DP-HCP08	P.DP-HDP08
Punch Shim 1.2mm 0.047"			P.DP-HCP12	P.DP-HDP12
Punch Shim pack (9 pcs)			P.DP-HCP	P.DP-HDP
Die Shim 0.4mm 0.016"	P.DP-HAD04	P.DP-HBD04	P.DP-HCD04	P.DP-HDD04
Die Shim 0.8mm 0.031"	P.DP-HAD08	P.DP-HBD08	P.DP-HCD08	P.DP-HDD08
Die Shim 1.2mm 0.047"	P.DP-HAD12	P.DP-HBD12	P.DP-HCD12	P.DP-HDD12
Die Shim pack (9 pcs)	P.DP-HAD	P.DP-HBD	P.DP-HCD	P.DP-HDD

Note: one pack include 3 pcs for different thickness

# Auto Tool Grinding Machine

## Model: AG-135



- Automatic sharpening CNC punch press tools.
- Tool grinding system programs autonomously.
- Precision grinding:  $\pm 0.005\text{mm}$ .

### Basic Parameters

Overall size	L x W x H	Unit: mm	900 x 800 x 1920
Weight		Unit: kg	1100
Voltage	380V AC	Unit: V	3-phase / 5-line
Max. power		Unit: KW	1.75

## A STATION

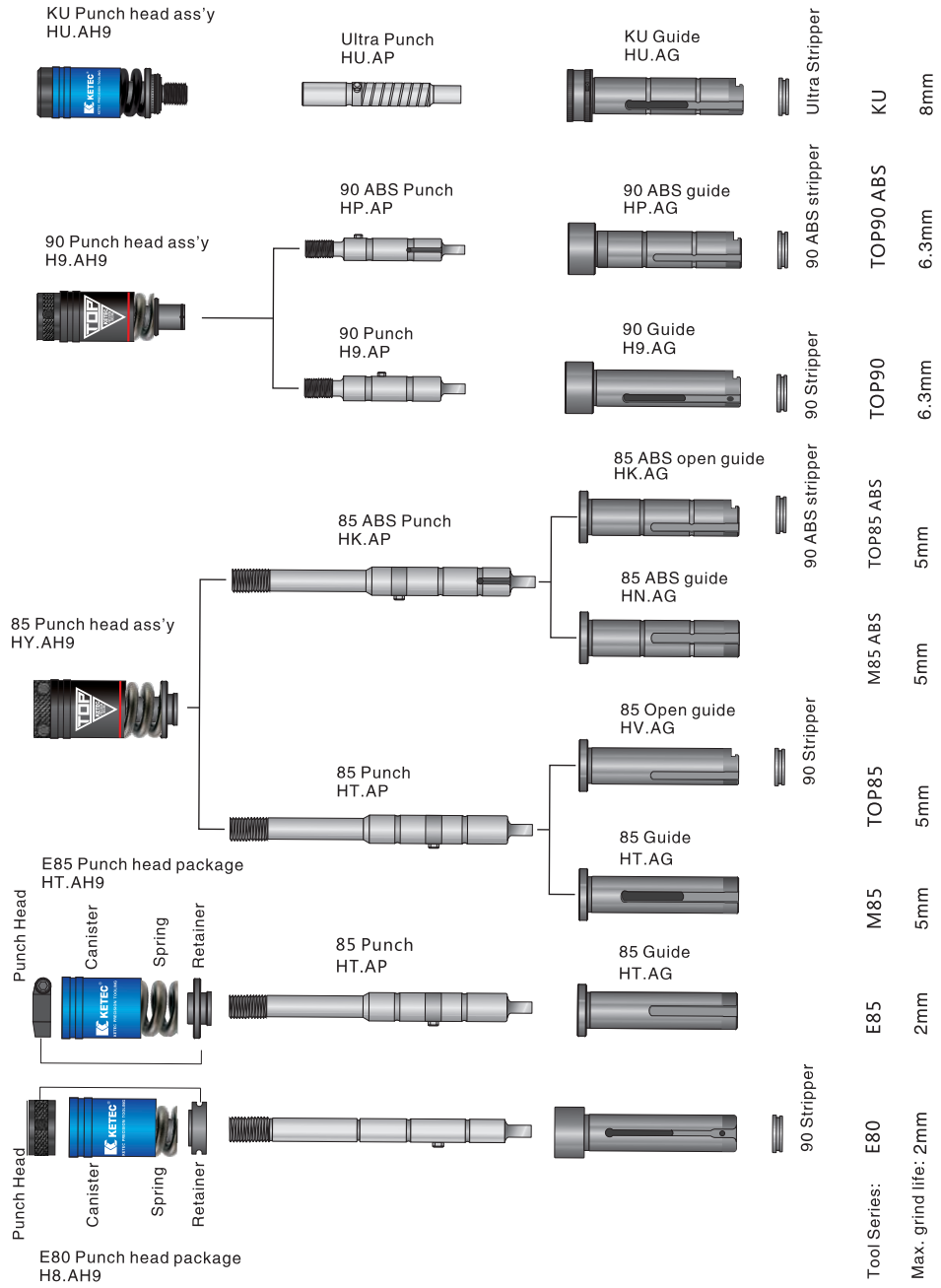

## B STATION

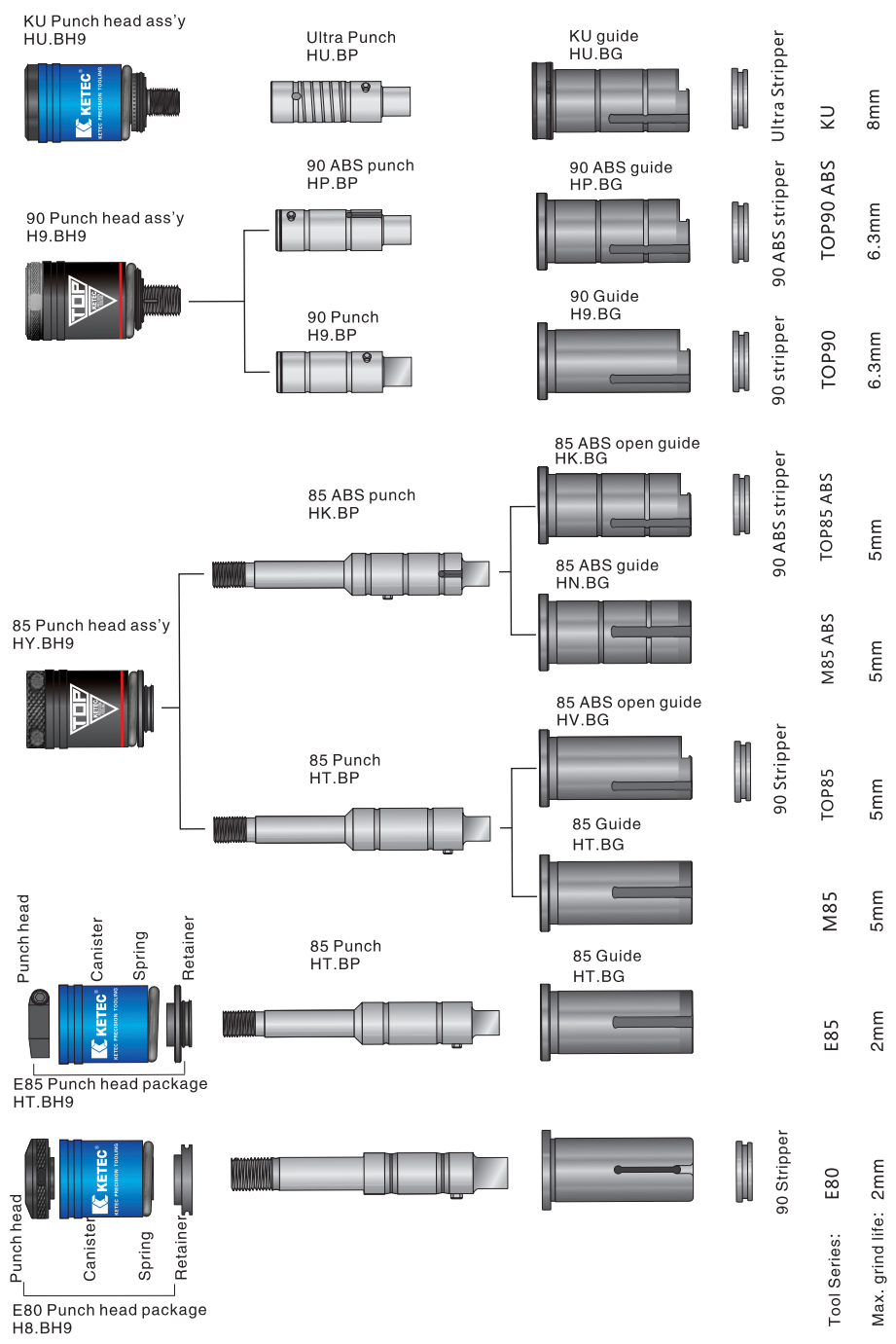

## C STATION

E85  
Guide ass'y  
HT.CC1

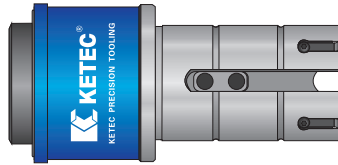

85 Punch  
HT.CP

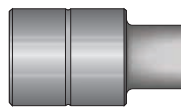

85 Stripper  
HT.CS



Tool series: E85  
Max. gring life: 2mm

TOP 85  
Guide ass'y  
HV.CC1

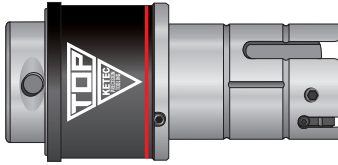

85 Punch  
HT.CP

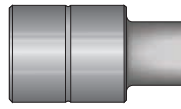

85 Stripper  
HT.CS



TOP85  
5~8mm

TOP85ABS  
Guide ass'y  
HK.CC1

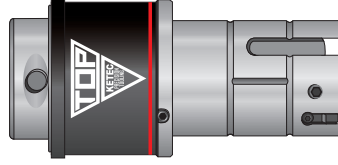

85 ABS Punch  
HK.CP

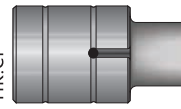

85 ABS stripper  
HK.CS



TOP85 ABS  
5~8mm

TOP90ABS  
Guide ass'y  
HP.CC1

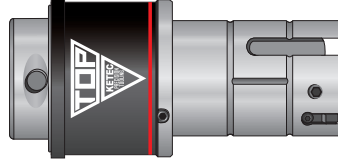

90 Punch  
H9.CP

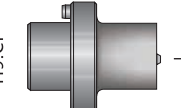

90 Stripper  
H9.CS







90 ABS stripper  
HP.CS

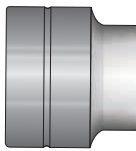
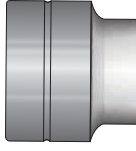

TOP90 ABS  
5~8mm

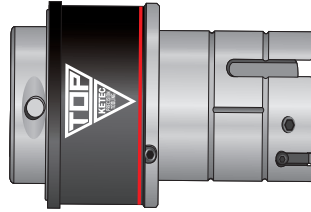
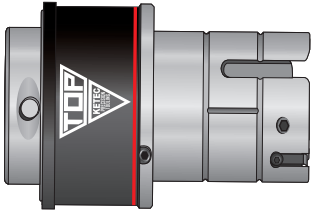
D STATION

<p>E85 Guide ass'y HT.DC1</p>		<p>85 Punch HT.DP</p>		<p>85 Stripper HT.DS</p>		<p>E85</p>	<p>2mm</p>
<p>TOP 85 Guide ass'y HV.DC1</p>		<p>85 Punch HT.DP</p>		<p>85 Stripper HT.DS</p>		<p>TOP85</p>	<p>5~8mm</p>
<p>TOP85ABS Guide ass'y HK.DC1</p>		<p>85 Punch HK.DP</p>		<p>85 ABS stripper HK.DS</p>		<p>TOP85 ABS</p>	<p>5~8mm</p>
<p>TOP90ABS Guide ass'y HP.DC1</p>		<p>90 Punch H9.DP</p>		<p>90 Stripper H9.DS</p>		<p>TOP90</p>	<p>5~8mm</p>
<p>TOP90 ABS</p>	<p>5~8mm</p>	<p>90 ABS stripper HP.DS</p>				<p>TOP90 ABS</p>	<p>5~8mm</p>

# SHAPE CLASSES



<b>STANDARD SHAPE</b>					
	Code: RE Name: Rectangle Size: B/A	Code: OB Name: Oblong Size: B/A	Code: SQ Name: Square Size: A	Code: SD Name: Single D Size: B/A	Code: DD Name: Double D Size: B/A
	Code: QD Name: Quad D Size: B/A	Code: QR Name: Quad R Size: B/A/R	Code: ET Name: Equilateral Triangle Size: A	Code: HX Name: Hexagon Size: A	Code: OT Name: Octagon Size: A

<b>GROUP A</b>					
	Code: A0 Name: Diamond Size: B/A	Code: A1 Name: Diamond Size: B/A/R	Code: A2 Name: Diamond Size: B/A/C	Code: A3 Name: Diamond Size: B/A/C/R	Code: A4 Name: Cable Connector Size: B/A/C/R
<b>GROUP B</b>					
	Code: A5 Name: Six Edges Size: B/A/C	Code: A6 Name: Eight Edges Size: C/B/A/D	Code: A7 Name: Triangle Size: B/A	Code: A8 Name: Triangle w/R Size: A/B/R	Code: A9 Name: Right Triangle Size: B/A

Code: B0 Name: Double R Size: B/A/C/D/R	Code: B1 Name: Tri-R Size: B/A/C/D/E	Code: B2 Name: Quad-R Size: B/A/D/E/F/G	Code: B3 Name: Ellipse Size: B/A/C/R	Code: B4 Name: Football Size: A/B	Code: B5 Name: Key Hole Size: A/B/C

<b>SPECIAL SHAPE</b>	Special shape follows the attached drawing
	CODE: FT

**SAME STATION TOOLING, SAME GROUP SHAPE, SAME PRICE!**

# GROUP C

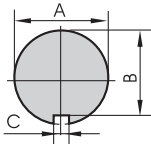
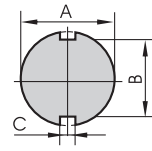
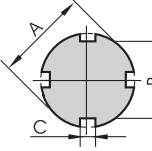
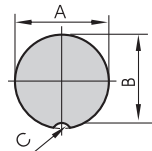
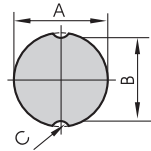
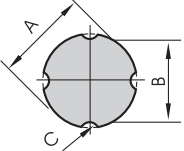
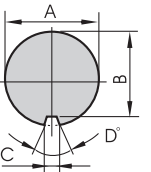
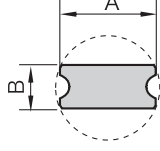
					
<p>Code: C0 Name: Key Way Size: C/B/A</p>	<p>Code: C1 Name: Double Key Way Size: C/B/A</p>	<p>Code: C2 Name: Quad Key Way Size: C/B/A</p>	<p>Code: C3 Name: Key Way Size: C/B/A</p>	<p>Code: C4 Name: Key Way Size: C/B/A</p>	<p>Code: C5 Name: Key Way Size: C/B/A</p>
					
<p>Code: C6 Name: Key Way Size: C/B/A/D</p>	<p>Code: C7 Name: Micro-joint Size: B/A</p>				

# GROUP D

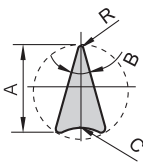
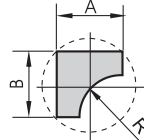
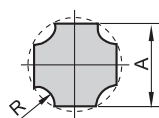
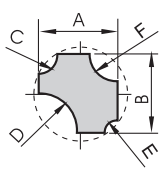
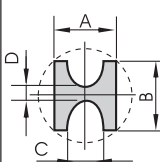
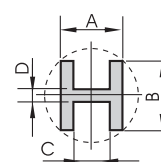
					
<p>Code: D0 Name: Triangle w/R Size: A/B/C/R</p>	<p>Code: D1 Name: One way radius Size: B/A/R</p>	<p>Code: D2 Name: Four way radius Size: A/R</p>	<p>Code: D3 Name: Four way radius Size: A/B/C/D/E/F</p>	<p>Code: D4 Name: H w/radius Size: D/C/B/A</p>	<p>Code: D5 Name: H shape Size: D/C/B/A</p>

# GROUP E F

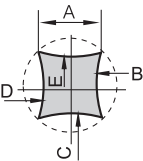
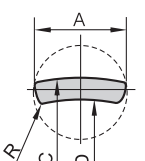
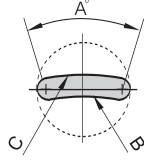
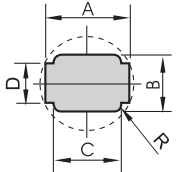
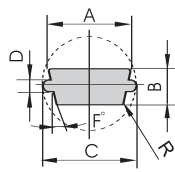
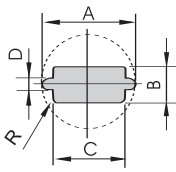
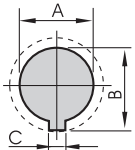
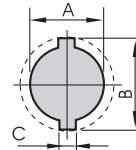
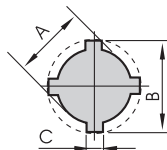
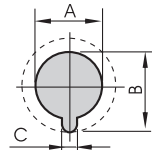
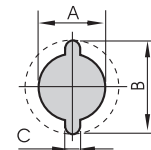
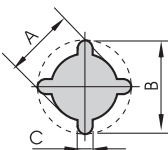
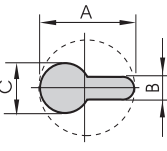
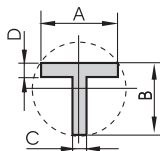
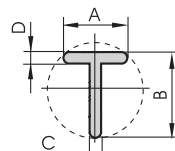
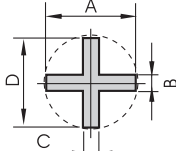
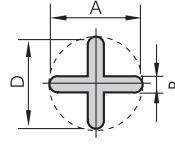
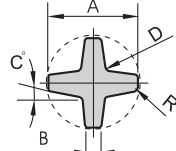
					
<p>Code: E0 Name: Four radius Size: A/B/C/D/E</p>	<p>Code: E1 Name: Banana Size: A/C/D/R</p>	<p>Code: E2 Name: Banana Size: B/C/A</p>	<p>Code: E3 Name: Connector Size: D/B/C/A/R</p>	<p>Code: E4 Name: Connector Size: D/B/A/C/F/R</p>	<p>Code: E5 Name: Connector Size: D/B/C/A/R</p>
					
<p>Code: E6 Name: Key Hole Size: C/A/B</p>	<p>Code: E7 Name: Key Hole Size: C/A/B</p>	<p>Code: E8 Name: Key Hole Size: C/A/B</p>	<p>Code: F0 Name: Key Hole Size: C/A/B</p>	<p>Code: F1 Name: Key Hole Size: C/A/B</p>	<p>Code: F2 Name: Key Hole Size: C/A/B</p>
					
<p>Code: F3 Name: Key Hole Size: B/C/A</p>	<p>Code: F4 Name: T shape Size: D/C/B/A</p>	<p>Code: F5 Name: T shape Size: D/C/A/B</p>	<p>Code: F6 Name: Cross Size: C/B/D/A</p>	<p>Code: F7 Name: Cross Size: B/A/D</p>	<p>Code: F8 Name: Cross Size: B/A/C/D/R</p>





WeChat of KETEC PRECISION TOOLING

More about KETEC PRECISION TOOLING, please enter

[Http://www.ketecool.com](http://www.ketecool.com)

KETEC has certified by the ISO 9001:2008 quality management system

# **KETEC<sup>®</sup>**

**Ketec Precision Tooling Co.,Ltd.**

Add: No.7,Lifeng Road., Mingzhu Industrial Park,Conghua, Guangzhou, China

P.O.Box: 510931

Tel: 0086 20 37965500 Fax: 0086 20 37965133

E-mail:international@ketecool.com

[Http://www.ketecool.com](http://www.ketecool.com)